



إيرام أغنيس الهندسية  
Eram Agnice Engineering

FIRE PROTECTION  
&  
MEP SERVICES

COMPANY PROFILE & PRE QUALIFICATION DOCUMENTS



# Contents

	<b>Introduction</b>	<b>04</b>
	<b>About Eram Group</b>	<b>05</b>
	<b>About Manappat Group</b>	<b>07</b>
	<b>Our Services</b>	<b>08</b>
	<b>Our Solutions</b>	<b>09</b>
	<b>Our Capabilities</b>	<b>11</b>

<b>Our Registrations &amp; Company Documents</b>	<b>13</b>
<b>Our Quality Policy</b>	<b>19</b>
<b>NFPA Membership</b>	<b>21</b>
<b>Our HSE Policy</b>	<b>23</b>
<b>Project References &amp; Completion Certificates</b>	<b>24</b>
<b>Site Photos</b>	<b>65</b>





ERAM GROUP

## Introduction

Eram Group is a leading player in Saudi Arabia offering construction, projects support and industrial services. Eram's Clientele include all leading Oil and Gas, Power, Mining, and EPC Companies in the GCC Region. Eram Group is now stepping into Fire EPC Services through a joint venture with Agnice International & Partners LLC.

Agnice is a leading fire engineering & contracting company with operations in KSA, Oman, UAE, Qatar (Under Incorporation) & India. Eram Agnice Engineering is promoted by Eram Group & Manappat Group.

Eram Agnice Engineering Specialises in the field of fire protection, fire detection, fire suppression & MEP Solutions on a turnkey basis. Eram Agnice Engineering offers its services and solutions to a range of sectors, some of which include Power (Including Nuclear Power Plants), Oil & Gas, Airports, Process & General Industries, Warehouses, & High rise buildings to name a few.

For over a decade engaged in fire engineering field, Agnice comes with expertise of completing more than 400 turnkey projects across the world.

# Eram Group

**Eram Group** is an entity of a number of leading businesses in industrial contracting, project management, Automotive, Health Care, IT, Manufacturing & Trading.

## KEY FACTS









- Commenced operations in India in 1985
- Headquartered in Al-Khobar, Saudi Arabia
- Annual Turnover of 1 Billion Saudi Riyal in 2011
- 12 SBU's and 23 Companies
- Presence in 10 Countries with 50+ Branches
- Employing more than 9000 people.

Eram Group operates across GCC, Europe & India, and is one among the highly diversified business conglomerate in the region.

## THE GLOBAL PRESENCE:

- 1985 India
- 1999 Kingdom of Saudi Arabia
- 2006 Kingdom of Bahrain
- 2007 State of Qatar
- 2008 United Arab Emirates
- 2010 United Kingdom
- 2011 Italy, Kuwait, Turkey
- 2012 Korea

Construction and Industrial Services SBU

 <p>Project Management Solutions</p>	 <p>Products Representation</p>	 <p>Aluminium Cladding Systems</p>	 <p>Hydraulic and Pneumatic</p>
 <p>Industrial Construction</p>	 <p>Industrial Maintenance</p>	 <p>HVAC Systems</p>	 <p>Equipment Rentals</p>

Offices in Al-Khobar, Jubail, Riyadh, Jeddah, Rabigh, Yanbu, Al-Khafji



Kindly visit [www.eramgroup-sa.com](http://www.eramgroup-sa.com) to explore more about us.

# Manappat Group

**Manappat Group** is a vibrant, versatile business house with an unrivalled portfolio of interests and investments across the Sultanate of Oman, United Arab Emirates, India, Saudi Arabia, Qatar and United Kingdom.

Kindly visit [www.manappat.com](http://www.manappat.com) to explore more about the group.

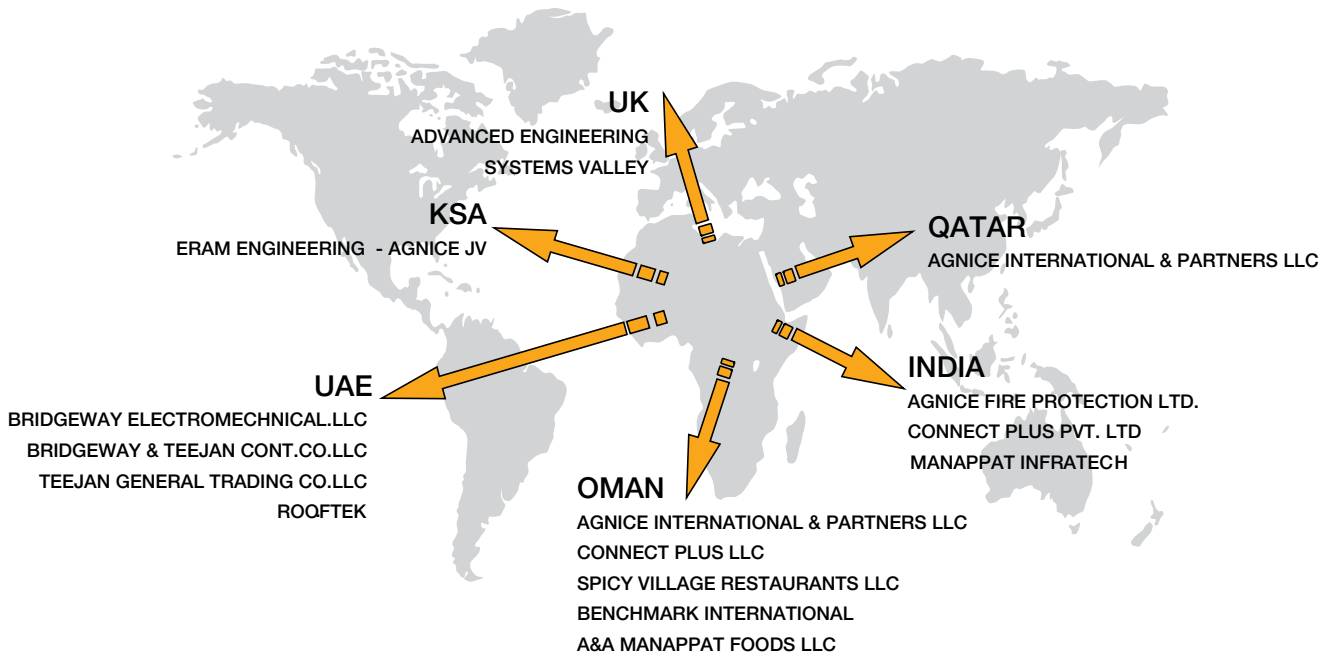

## Agnice Overview

Over 15 years experience in fire protection systems from concept to commissioning on turnkey basis.

Excellent engineering skills, uncompromising quality control and sizable project team focussed on erection and commissioning.

Executed jobs as per NFPA standards, European standards, OISD standards, LPCB standards, TAC standards

Executed more than 400 turnkey projects around the world.





ERAM GROUP

# Turn key Services from Eram Agnice Engineering

## FIRE EPC Services Including

- Fire Risk Evaluation
- System Design & Engineering
- Quantity Surveying
- Procurement
- Mechanical Fabrication & Erection
- Testing and Commissioning
- Maintenance and Support

## MEP Services Including

- Plant Construction
- Pipe line Construction
- Structural Construction
- Electrical & Instrumentation works
- HVAC System Installation
- Plumbing & Drainage Services

# Turn key Solutions from Eram AgnICE Engineering

## Fire Detection & Alarm Systems

### High Sensitivity Smoke Detection Systems, including:

- Photo Electric Smoke Detection
- Ionization Smoke Detection
- Beam Detectors
- VESDA

### Heat Detection Systems, including:

- Fixed Temperature Heat Detection
- Rate of Rising Temperature Heat Detection
- Probe Type Heat Detection
- Linear Heat Detection

## UV/IR Flame Detection Systems

Toxic Gas Detection, including Hydrogen Gas Detection and Hydrogen Sulphide Gas Detection.

## Fire-Fighting Systems

- **Hydrant Systems**  
A semi-automatic system, consisting of pressurized waterlines through pumps, which is recommended for use in all types of industries and commercial establishments.
- **High Velocity Water spray Systems**  
An automatic fire suppression system for special applications such as transformer protection, boilers, burner fronts and lube oil tanks.
- **Medium Velocity Water spray Systems**  
An automatic total flooding system for use in coal conveyor systems, cable galleries, LPG bullets and more...

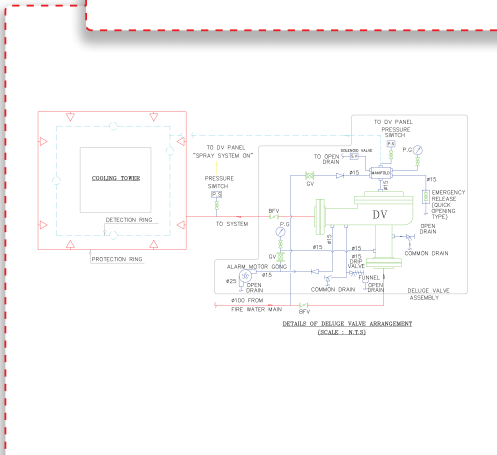
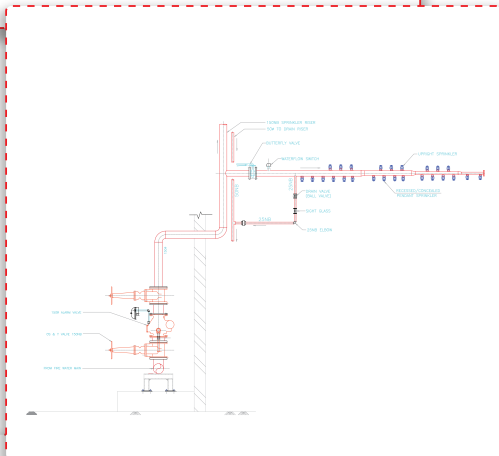
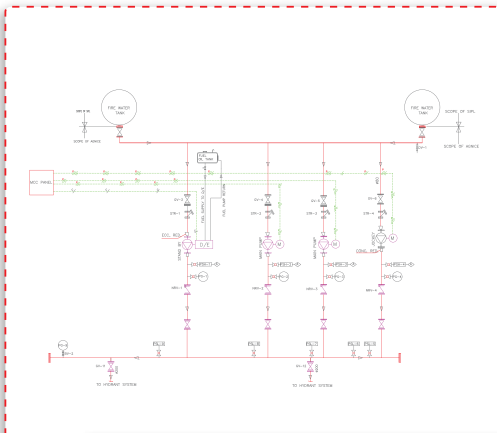

- Foam Systems**  
 Used for oil fire applications, this system separates the fuel from the air by blanketing foam over the surface of the oil.
- Sprinkler System**  
 Used for localized fire applications, this system is ideal for use in factories, commercial buildings and the home.
- Deluge Systems**  
 Similar to an automatic sprinkler system, except all nozzles discharge together, this system protects areas where fire is likely to spread rapidly.
- Water Mist Systems**  
 By converting pure water into a fine spray mist, this environmentally friendly system extinguishes fire without hurting or damaging people or property.

## Fire Suppression Systems

- Inergen Systems**  
 Ideal for use in enclosures such as server rooms and control rooms, this system floods clean agent gases (N<sub>2</sub> and Ar) into the area at risk; extinguishing flames by lowering the oxygen level, whilst maintaining breathable conditions.
- IG100**  
 A colorless, odorless, electrically non-conductive gas with a density equivalent to air; extinguishes fire by reducing the oxygen concentration within the area at risk.
- HPCO<sub>2</sub>**  
 An automatic gas suppression system used mainly in unmanned areas such as oil cellars, hydraulic rooms and automated paint shops.
- LPCO<sub>2</sub>**  
 A total flooding system for use in areas where CO<sub>2</sub> is held at -18°C at 20- 25 bar pressure.
- Sapphire Systems**  
 A clean agent system that uses Novec 1230 fire protection fluid to quickly suppress fires and protect sensitive equipment without damaging the environment.
- FM200**  
 A clean agent system that uses HFC227 fire protection fluid to quickly suppress fires and protect sensitive equipment without damaging the environment.
- DCP Skid Systems**  
 For use in extinguishing fire involving bulk chemical agents, liquefied gases.

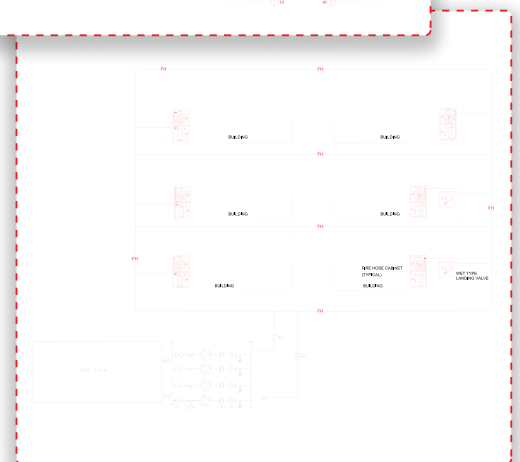
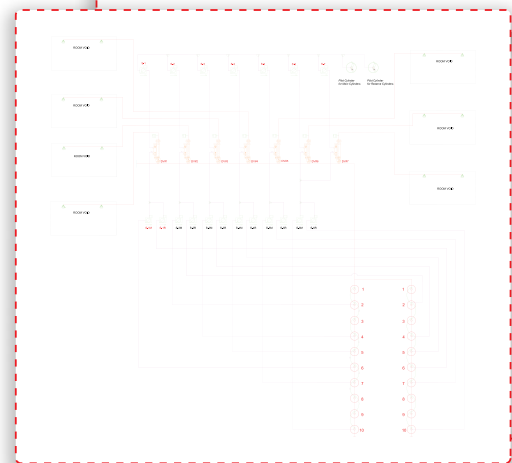
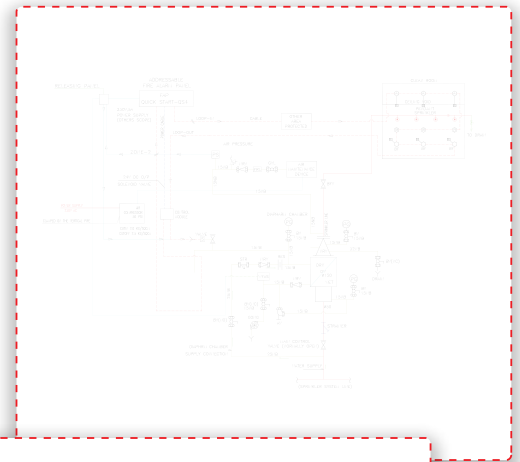

# EPC Capabilities

Excellent engineering skills, uncompromising quality control and sizable project team focussed on erection and commissioning.

## ENGINEERING CAPABILITIES

Manned by highly qualified design professionals with excellent capability in the following area

- Pre-Bid Engineering
- Design, Detailed Engineering, Hydraulic Calculation
- Supply Chain Management Using Customised Software
- Fabrication & Installation
- Testing & Commissioning
- Training & Operational Support
- Maintenance Support and Upgrading of Existing Systems

## EXCELLENT CAD FACILITIES

- AutoCAD
- Pipe net
- Sprink cad
- CO2 flow calculation
- Inert Gas Flow Calculation Software
- FM200 Flow Calculation Software from Tyco(Hughes associates Inc-Fire Service & Egg)

## CAPABILITY FOR IN HOUSE ASSEMBLY

- Custom Built Control Panels
- Control cum Annunciation Panel
- Motor Control Center
- Diesel Engine control Panel cum Battery Charger
- Diversion Dampers
- Y Type Strainer
- Basket Type Strainer
- CO2 System
  - Frame Assembly
  - Manifold
  - Discharge Nozzles
  - Online weighing Unit
  - Selector Valves
  - Gas Release Panels



# Registrations & Company Documents

Commercial Registration No: 2051033343

ISO Ref No: IND 12.3029/U/Q

Sabic Vendor Code: 503387

Aramco Vendor Code: 10031112

SEC Vendor Code: 5001200



# المملكة العربية السعودية



وزارة الداخلية  
المديرية العامة للدفاع المدني  
مديرية الدفاع المدني بالمنطقة الشرقية  
إدارة الدفاع المدني بالخبر  
العمليات - قسم السلامة

## تصريح الدفاع المدني

رقم التصريح: ١٤٣٤٠٠٨٢١١٧١٦٥٠١ نوع التصريح: جديد الفئة: ز  
تاريخ الإصدار: ١٤٣٤/٠٨/٢١ هـ تاريخ الإنتهاء: ١٤٣٧/٠٨/٢١ هـ المدة: ثلاث سنوات  
اسم صاحب التصريح: شركة ابرام لأنظمة الاطفاء والسلامة  
الاسم التجاري: شركة ابرام لأنظمة الاطفاء والسلامة  
نوع النشاط: صيانة وتركيب أنظمة مكافحة الحريق  
العنوان: الخبر شارع: الملك عبدالعزيز  
التقاطع: برج السبيعي المساحة: ٢١٤٠ عدد الأدوار: الثامن

## وسائل السلامة المتوفرة

العدد	النوع	العدد	النوع
٣	أنوار طوارئ	٤	كاشف دخان
١	صيدلية إسعاف أولية		كاشف تسرب غاز
٦	لوحات تحذيرية		أجراس إنذار
	مخارج طوارئ		نظام الرش الأتوماتيكي
			معدات الحماية الشخصية
			مولد كهربائي احتياطي / ديزل
			شبكة إنذار حريق مبكر أوتوماتيكية بلوحة تحكم

العدد	السعة بالبرطل	نوع الطفايات
٣	٢٠	بودرة متعددة الأغراض
٣	١٥	ثاني أكسيد الكربون
		هالون
		مياه
		طفاية على عجل
		خراطيم مياه حريق بطول: مقاس:
		مضخة حريق أوتوماتيكية تعمل على الديزل بقوة

مفتش السلامة

رئيس قسم السلامة

الاسم: ناصر بن سليمان الهندي

الاسم: محمد بن مسفر الموسى

الاسم: أسامة بن يحيى الجبلي

الرتبة: عقيد

الرتبة: عقيد

الرتبة: رقيب أول

التوقيع:

التوقيع:

التوقيع:

١٥٧

٢١

٤

الدرجة : الثانية

رقم العضوية: 67971

تشهد الغرفة التجارية الصناعية للمنطقة الشرقية بأن:

## ايرام لأنظمة الإطفاء والسلامة

صندوق بريد: 2051051503 رقم السجل التجاري:

مسجل لديها هذا العام وينتهي سريان هذه الشهادة في نهاية عام 2013 م

صدرت في: 2013/1/29 م الموافق: 1434/03/17 هـ

رقم السند: 13 / 1-38910375 تاريخ الإصدار: 2013/01/27

نعمل معاً... لخدم أفضل

الرقم الموحد ١٦٣٠٠٠١٣٠٠٠  
فاكس ٨٥٧٠٦٠٧

غرفة الشرقية  
ASHARQIA CHAMBER  
مركز الخدمات  
الخاصة

التوقيع





Eastern R Office

الرقم ١٥٢١٩٥٤١

مكتب المنطقة الشرقية

التاريخ ١٤٣٤/٠٩/٠١

الموافق ٢٠١٣/٠٧/٠٩

شهادة

## منشأة غير خاضعة لأحكام النظام

إسم المنشأة : شركة ايرام لانظمة الاطفاء والسلامة
ص.ب : ٤٩٥٥ الخبر ٣١٩٥٢
السعودية

رقم الإشتراك : ٥٠٦٨٨٧٧٤٧	رقم السجل التجاري : ٢٠٥١٠٥١٥٠٣
مصدره: الدمام	

رقما	كتابة	
٠	صفر	عدد المشتركين السعوديين
٠	صفر	عدد المشتركين غير السعوديين
٠	صفر	المجموع

تشهد المؤسسة العامة للتأمينات الاجتماعية بأن المنشأة المذكورة أعلاه قد أوفت بالتزاماتها تجاه المؤسسة وفق البيانات المقدمة منها حتى تاريخ إصدار هذه الشهادة ، والتي تم منحها لتقدمها لأية جهة تطلبها ، وهي صالحة لجميع الأغراض التي نص عليها نظام التأمينات الاجتماعية في المادة (٦/١٩) منه .

هذه الشهادة سارية المفعول حتى ١٤٣٥/٠٣/٠١ هـ.

(الأول من شهر ربيع الأول لعام ألف و اربعمئة وخمسة و ثلاثون هجرية )

مدير عام مكتب المنطقة الشرقية

محمد بن عبدالمحسن الدليل



\* لايعتد إلا بأصل هذه الشهادة لجميع الأغراض.

\* تعتبر هذه الشهادة لاغية في حالة وجود كشط أو شطب عليها.

\* إن تصنيف منشآتكم في برنامج نطاقات خاضع لأحكام ذلك البرنامج .



بِسْمِ اللَّهِ الرَّحْمَنِ الرَّحِيمِ

المملكة العربية السعودية  
وزارة المالية  
مصلحة الزكاة والدخل



نموذج (ش/٣)

رقم الشهادة : ٤٤٨٤

رقم الملف : ٤٢٧٩٦٠١٠٥

التاريخ : ١٩ / ٠٤ / ١٤٣١

الرقم المالي : ١٠٢٠٤٤٤٢٨

### شهادة

تشهد مصلحة الزكاة والدخل بأن المكلف / مؤسسة ايرام للمقاولات لصاحبها عبدالله عبدالعزيز التويجري.

سجل منفي رقم ١٠١٩٨٧٧٣٨٨ و سجل تجاري رقم ٢٠٥١٠٣٣٤٣

قدم إقراره عن الفترة المنتهية في ١٤٣٠/١٢/٣٠ هـ.

وقد منح هذه الشهادة لتمكينه من إنهاء جميع معاملاته بما في ذلك صرف مستحقاته النهائية عن العقود .

يسري مفعول هذه الشهادة حتى تاريخ ١٤٣٢/٠٤/٣٠ هـ .

( اليوم 'الثلاثون' من شهر ربيع الآخر سنة الف و اربعمائة واثان وثلاثون' هجري )

و فروعه الموضحة أدناه :-

رقم السجل/ الرخصة	اسم الفرع	المدينة
١٤٢٦	تابع السجل التجاري للمقاولات العامة	الخبير
٢٠٥١٠٣٣٤٤	مؤسسة ايرام للتجارة والمقاولات	الخبير

*(Handwritten signature)*

الختم الرسمي



الوظيفة : مدير عام فرع المصلحة بالدمام

الإسم : صالح بن بخير الاستداف

التوقيع :

*(Handwritten signature)*

٤٤٨٤ ٤٤٤٢٨

Kingdom of Saudi Arabia  
Ministry of Labour



المملكة العربية السعودية  
وزارة العمل

قسم التوظيف

سنة ١٤٣٥

يفيد مكتب العمل بالخبر أن: مؤسسة ابرام للمقاولات العامة لصاحبها عبدالله التويجري، رقم الملف: ١٥ - ١٩٨٧٤

ملتزمة بما لوجب تحقيق نسبة السعودة المحددة

لا يسري عليها تطبيق النسبة المطلوبة لزيادة السعودة.

غير ملتزمة بما يوجب تحقيق نسبة السعودة.

وفد منحت هذه الشهادة وفق تعميم صاحب السمو الملكي وزير الداخلية رقم ٤٧٥/ع. وتاريخ ١٤٢١/٦/١٨ هـ، وذلك بناءً على طلب المسأة، وتعتبر سارية المفعول لمدة **سنة شهور فقط** اعتباراً من ١٤٣٣/٠١/٠٩ هـ.

وتقبلوا فائق التحية...

مدير المكتب: مفرح بن عبدالله القحطاني

التوقيع:



مدير المكتب: مفرح بن عبدالله القحطاني



ERAM GROUP

أرامكو السعودية  
Saudi Aramco



December 19, 2004

YOUR SAUDI ARAMCO VENDOR  
REGISTRATION NUMBER: 10031112

ERAM CONTRACTING EST.  
P.O. BOX. 76629 AL KHOBAR 31952  
SAUDI ARABIA

Dear Sir:

Thank you for your interest in performing work under contract to Saudi Aramco. Your file now contains the required registration information.

It is important to note that this registration merely provides Saudi Aramco with current contact and other basic information about your company. This registration is different from contractor prequalification which is performed separately in connection with a specific contract or group of similar contracts.

The method Saudi Aramco uses to prequalify and select bidders for each contract depends on the contract's complexity and urgency in addition to the number of potentially qualified contractors for the required work. A brief explanation of Saudi Aramco's Bid Slate Development methods is available in the Contracting Policies and Procedures section of Contracting's Internet Website. Our Web Site address is as follows:

Web site: [www.saudiaramco.com](http://www.saudiaramco.com)  
Select: E-business  
Select: Contracting

We would like to take this opportunity to remind you to regularly update your registration information with Saudi Aramco, at least once a year. Should you require information concerning your file with Saudi Aramco, please contact our Contractor Relations Group, R-A162, North Park #2, Bldg. #3301, Wing "A", Dhahran, Telephone Nos. 874-2328 or 874-2295; Fax no. 874-2310.

We appreciate your interest in doing business with Saudi Aramco and wish you the best of success.

Sincerely yours,

  
S.M. AL-DOSSARY, Manager  
Contracting Department

# Quality Policy

QUALITY IS THE HALLMARK OF OUR ENTERPRISE AND CUSTOMER DELIGHT IS THE GOAL OF OUR EFFORTS WITH CONTINUAL IMPROVEMENT AS OUR PLATFORM

We take pride in delivering a truly world-class service and ensure our work always meets the highest possible international standards. So when you partner with us on a fire protection and security solutions project, we'll take an uncompromising approach to quality at all stages of the project: from planning and commissioning to implementation and support.

Our commitment to putting quality first and always providing the best possible service to customers has been recognized with the award of ISO 9001 Bureau Veritas Certification for adherence to global quality standards.



ERAM GROUP

**BUREAU VERITAS**  
Certification



*Certification*

*Awarded to*

**ERAM ENGINEERING**

(Division of ERAM Contracting Est.)

Suit No.:1334, 3<sup>rd</sup> Floor, Hail Center, Khobar – Dammam Highway  
P.O. Box 76629 AL KHOBAR 31952, Kingdom of Saudi Arabia

*Bureau Veritas Certification certify that the Management System of the above organisation has been audited and found to be in accordance with the requirements of the standard detailed below*

*STANDARD*

**ISO 9001:2008**

*SCOPE OF SUPPLY*

**TECHNICAL SUPPORT SERVICES RELATED TO INSPECTION AND CONTRACTING**

*PERMITTED EXCLUSIONS (S): Clause 7.3 – Design and Development, Clause 7.6 – Control of Measuring and Monitoring Equipment*

*Original Approval Date: 20 DECEMBER 2005*

*Certificate Valid Till: 19 DECEMBER 2011*

*New Certificate Approval Date & Valid from: 06 MARCH 2012*

*Subject to the continued satisfactory operation of the organisation's Management System, this certificate is valid until:*

**05 MARCH 2015**

*To check this certificate validity please call:*

**+966 2 6374145**

*Further clarifications regarding the scope of this certificate and the applicability of the Management System requirements may be obtained by consulting the organisation.*

**TALIB HUSSAIN**  
Deputy Country Chief Executive

*Bureau Veritas Certification using the accreditation certificate number 030*



008

*Date: 06 MARCH 2012*

*Certificate Number: IND 12.3029/U/Q*

*Managing Office Address: Dhahran Street, Tawuni Building, Floor 5, Plot 508, Al Khobar, P.O.Box 20149, Thopha 31952, Kingdom of Saudi Arabia.*

*Certification Office Address: "Marwah Centre" 6th Floor, Krihondal Marwah Marg, Opp. Asa Industrial Estate, Off Sakhi Vihar Road, Andheri (East), Mumbai – 400 072, India*



NFPA Membership





ERAM GROUP

# HSE (Health, Safety & Environment) Policy

Eram Engineering will maintain a rigorous loss prevention program aiming to prevent human distress and financial loss. Eram is committed to provide safe and healthy working atmosphere to all its employees and protecting the environment from all its activities, as an integral part of business performance through.

- Systematic approach to HSE management, designed to ensure compliance with legal requirements and to achieve continuous performance improvement.
- Setting targets for improvement and measures, appraises and reports on HSE performance.
- Providing adequate training to all employees on HSE aspects.
- Periodic review of HSE management system to ensure its continuing suitability, adequacy and effectiveness.

In pursuit of excellence, Eram has adopted stringent Quality Management System and Occupational Health and Safety Assessment System which does not introduce any standard lower than those in the Saudi ARAMCO program but allows for adaptation to meet local requirements and conditions. Moreover this safety program is a supplement to the Saudi ARAMCO.

HSE Certificate from GS E&C  
for Sohar II Power Plant, Oman





# Project References & Completion Certificates

## Our Major Projects in the Middle East

PROJECT	CLIENT/ CONSULTANT / MAIN CONTRACTOR
FIRE PROTECTION SYSTEM PREVENTIVE & CORRECTIVE MAINTENANCE.	SABIC/IBN-ZAHR
FIRE PROTECTION WORK FOR BUILDINGS AT BARAKA NUCLEAR POWER PLANT , SILA ABUDHABI	HYUNDAI ENGINEERING & CONSTRUCTION CO LTD & SAMSUNG C&T CORPORATION JV
EPC OF FFS FOR OIL STORAGE TERMINAL FACILITIES PHASE 4,5,6.	INDIAN OIL TANKING / OOT- ODFJELL
EPC OF FFS & FAS FOR SALALAH INTERNATIONAL AIRPORT - MC5 PACKAGE.	LARSEN & TOUBRO LIMITED (OMAN BRANCH)
SOHAR II IPP PROJECT - ITC OF FPS & STRUCTURAL WORKS	GS ENGINEERING & CONSTRUCTION
REVAMPING OF HYDRANT , FOAM & DELUGE SYSTEM AT MARMUL AND FOAM SYSTEM AT NIMR FOR PDO	WORLEY PARSONS ARABIAN INDUSTRIES JV
PROVISION FOR EPC OF FIRE FIGHTING SYSTEM IN B-BLOCK STATION, DALEEL PETROLEUM	ATTILA DOGAN CONSTRUCTION & INSTALLATION CO INC
SUPPLY OF FIRE FIGHTING EQUIPMENTS - MC3 DEVELOPMENT OF MUSCAT INTERNATIONAL AIRPORT	BAHWAN ENGINEERING CO LLC
DESIGN,ENGINEERING, SUPPLY, INSTALLATION, TESTING AND COMMISSIONING OF FFS FOR FUEL FARM FACILITY FOR AL DUQUM INTERNATIONAL AIRPORT PROJECT.	MERIT INTERNATIONAL - CEGELEC JV/HANJIN
SITC OF FIRE FIGHTING SYSTEM - SIDI WAREHOUSE AT PLOT NO 817 AT AL ANSAB, BAUSHER.	AL HAJIRY TRADING LLC
EPC OF FPS FOR 132/33KV GRID STATION AT QURUM & MATTRAH	GALFAR ENGINEERING & CONTRACTING SAOG
EPC OF FPS SLOP & SLUDGE FACILITIES AT DUQM	UNIQUE TILE SERVICES LLC
DESIGN, SUPPLY, ENGINEERING, ROP APPROVAL, INSTALLATION, TESTING, COMMISSIONING & HANDINGOVER	AL MADINA CEMENTS COMPANY LLC

## Our Major Projects in the Middle East

PROJECT	CLIENT/ CONSULTANT / MAIN CONTRACTOR
DESIGN & ENGINEERING OF FIRE PROTECTION SYSTEM FOR THE OMAN ALUMINIUM ROLLING PLANT.	FATA SPA
DSITC & OBTAINING ROP CIVIL DEFENCE APPROVALS FOR THE FIRE PROTECTION & DETECTION FOR MEDICAL STORE AT SQUH.	AL ADRAK TRADING & CONTRACTING CO LLC
DESIGN, SUPPLY, ENGINEERING, SUPERVISION, TESTING, COMMISSIONING & HANDINGOVER OF INERT GAS SYSTEM FOR MC1 MUSCAT INTERNATIONAL AIRPORT	BAHWAN ENGINEERING CO LLC
SUPPLY OF FIRE ALARM SYSTEM - KOCHI REGAS FACILITIES PETRONET LNG PROJECT	CTCI OVERSEAS CORP. LTD
STC OF FIRE DETECTION & ALARM SYSTEM - COMMERCIAL / RESIDENTIAL COMPLEX AT AL KHUWAIIR (PANORAMA).	OMAN SHAPOORJI CONSTRUCTION CO. LLC
DESIGN & ENGINEERING FOR FIRE PROTECTION SYSTEM - MARMUL CENTRAL DEVELOPMENT PHASE - III	GULF PETROCHEMICAL SERVICES
STC OF FIRE DETECTION & ALARM SYSTEM - HOLIDAY INN HOTEL, MUSCAT.	ELEMEC ELECTRICAL CONTRACTING LLC
AUTOMATIC WATER SPRAY SYSTEM FOR 125MVA TRANSFORMER 01 NO EACH AT MAWELLAH & WADI KABIR SUB STATION.	POWERTECH ENGINEERING LLC
TRANSFORMER PROTECTION SYSTEM FOR 132/33KV GRID STATION AT YITTI	BAHWAN ENGINEERING CO LLC
DISTC & ROP APPROVAL OF FPS SERVICES FOR ASEEB STP	HYUNDAI ROTEM COMPANY
MEP WORKS FOR 3 NOS. LABOUR CAMP ACCOMMOATION BUILDINGS IN RAS AL KHAIMA	ARCHIRODON CONSTRUCTION (OVERSEAS) CO.

## Our Major Projects in the Middle East

PROJECT	CLIENT/ CONSULTANT / MAIN CONTRACTOR
DESIGN & ROP APPROVAL OF FFS FOR AREEJ FACTORY AT RUSAYL	AREEJ VEGETABLE OILS & DERIVATIVES S.A.O.G
SUPPLY OF FAS COMPONENTS FOR VARIOUS PROJECTS.	DRAKE & SCULL INTERNATIONAL LLC
SHADEED STEEL SOHAR - SUPPLY OF MOBILE FOAM UNITS	SHADEED IRON & STEEL CO. LLC
SUPPLY OF FDA FOR OXY MUKHAIZNA PROJECT	AL RAFAA TRADING & CONTRACTING LLC
REPLACEMENT OF D.V IN NEW SOLVENT STORAGE AREA	JOTUN PAINTS FACTORY
OMIFCO - FIRE PROOF CABLES & FDA SPARES	OMAN INDIA FERTILISER COMPANY S.A.O.C
SUPPLY & TESTING OF FIRE ALARM & FIRE FIGHTING EQUIPMENTS FOR SOHAR SUBSTATION	LARSEN & TOUBRO (OMAN)
BARKA II IPP - SUPPLY & REVAMPING OF SIMPLEX FAS	SUEZ TRACTEBEL OPERATION & MAINTENANCE OMAN LLC
SUPPLY OF FIRE ALARM EQUIPMENTS	OMAN METHONAL COMPANY LLC
SUPPLY REVAMPING TESTING COMMISHIONING OF FAS FOR SOHAR ALUMINIUM COMPANY	SOHAR ALUMINIUM COMPANY LLC
DEMOLISHING & TERMINATE THE ELEVEN (11) OLD LOW VOLTAGE MOTOR CONTROL CENTRE (LVMCC) AND REPLACE NEW 11 NOS. LOW VOLTAGE MOTOR CONTROL CENTRE	WESCOSA/PETROKEMYA
PROCUREMENT & INSTALLATION OF FLOW CONTROL VALVE	SABIC/AL-BAYRONI
SUPPLY & INSTALLATION OF 4INCHES HOSE FOR WASTE WATER LINE FROM PLANT -4 LAGOON TO UTILITY AREA	SABIC/AR-RAZI
REMOVAL & RE-INSTALLATION OF BOILER INTERNALS, BOROSCOPE SERVICES R-STAMP FORMALITIES	THERMAX

## Our Major Projects in the Middle East

PROJECT	CLIENT/ CONSULTANT / MAIN CONTRACTOR
INSTALLATION OF FSE AIR COMPRESSOR,CHILLER UNIT PUMP SKID AND INTERCONNECTING PIPING WORKS @ SAUDI ARABIAN AIRLINES JET PROPULSION CENTER, JEDDA KSA	FS ELLIOT
SPECIAL WELDING CONSULTANT/WELDER SUPPORT FOR INSPECTION,TESTING,REPAIR, AND REPLACEMENT OF STYRENE-I PLANT EXPANSION JOINTS	SABIC/SADAF
SUPPLY OF CROWN PIECE FOR BI-10-3040 5JKT	STAR SAIPEM
FABRICATION OF TROUGH PLATE	SABIC/AR-RAZI
MODIFCATION OF THE INSTRUMENT AIR PIPE FOR HADEED SHUTDOWN	SABIC/HADEED
INSTALLATION OF 3 LEVEL TRANSMITTER (DP TYPE) ON STEAM DRUM	GLOBAL UNIONS INDUSTRIAL SUPPORT SERVICES EST.
HEADER REPAIR WORKS 55 NOS. REACTOR THERMOWELL, SS310 INSTRUMENTATION FLANGES	SABIC/IBN-ZAHR
SUPPLY OF 6» 80SCH. PIPE FITTINGS,FABRICATION OF PIPE LINE	SABIC/AL-BAYRONI
SS321 WELDING SERVICES FOR IBN-ZAHR	SABIC/IBN-ZAHR
INSTALLATION OF 8 NOS. OF EMERSON TRANSMITTERS & 1 NO. OF WIRELESS GATEWAY	PROCOL/SADAF
ROLLING OF PLATE FOR MNF 392 JACKET	ESS/STAR
SUPPLY, REPLACE EXISTING 8» INLET PIPE WITH SCH 80S SA312-TP304 MATERIAL	SABIC/SHARQ
RECTIFICATION AND REPLACEMENT OF THERMOCOUPLES AND THERMOCOUPLES CABLES (SHUTDOWN)	SABIC/IBN-ZAHR

## Our Major Projects in the Middle East

PROJECT	CLIENT/ CONSULTANT / MAIN CONTRACTOR
SUPPLY & FABRICATION OF STAINLESS STEEL PERFORATED SHEET	SABIC/AR-RAZI
INSTALLATION OF GAS DETECTOR TO HC-501A/B IN PLANT-I DISTILLATION AREA PCR-1688	SABIC/AR-RAZI
INSTALLATION OF TWO LEVEL TRANSMITTER IN TK-1630 & TK-1631 AS PER PCR-S1670 & 1671, AND INSTALL FLOW TRANSMITTER FI-619 AS PER PCR-1604	SABIC/AR-RAZI
INSPECTION AND OVERHAUL UNIT COVERING ELECTRICAL WIRING, CONTACTS, CONNECTIONS, RELAYS, BATTERY SYSTEM	GAS ARABIAN SERVICES
CABLE RETERMINATION OF PP-3 CYCLE GAS COMPRESSOR (320-MK-01) (SUPPLY OF MATERIALS, TESTING & COMMISSIONING)	SABIC/IBN-ZAHR
FABRICATION AND SUPPLY OF COUNTER BALANCING SYSTEMS	SABIC/AR-RAZI
REMOVING 6 EXISTING LINE AND INSTALLING 6 WW FLEXIBLE HOSE FROM THE TOP OF THE TANK TO THE POT AT AR-RAZI V	SABIC/AR-RAZI
CYLINDER BORE CRANK END GLAND HOUSING BORE TO BE INCREASE FROM 56MM TO 58MM	SABIC/SHARQ
SUPPLY OF FIBER OPTIC CABLE 12MM OUT DOOR TYPE (TAPE ARMOR)	YOKOGAWA
SUPPLY OF MARINITE P CALCIUM	MEBCO
WELDING SERVICES PROVIDED TO IBN-ZAHR	SABIC/IBN-ZAHR
BUILDUP AND MACHINING OF RING GASKET SEAL GROOVE	SABIC/AR-RAZI
FABRICATION OF SUPPORT BEAMS 2 NOS. WITH 2 NOS M30X950 LONG TIE ROD	GAS ARABIAN SERVICES

## Our Major Projects in the Middle East

PROJECT	CLIENT/ CONSULTANT / MAIN CONTRACTOR
SOUTH SHOWROOMS, OFFICES AND WAREHOUSE FOR JEBEL ALI FREE ZONE AUTHORITY (68 NOS)	JAFZA/AL WASL AL JADEED CONSULTANTS / SYSTEM CONSTRUCT
CONSTRUCTION OF STEEL CASTING FACTORY & G + M OFFICE BUILDING FOR M/S. INTERNATIONAL QUALITY STEEL CASTING CO. ON PLOT NO: 598 - 917 AT DUBAI INVESTMENT PARK, DUBAI	SEMAC CONSULTANTS
JOTUN PAINTS, DUBAI (PHASE III)	PAXKENT INTERNATIONAL
CAPEX FACTORY BUILDING	EEC / PAX KENT INTERNATIONAL
LAGOONS SALES CENTER OFFICE BUILDING FOR SAMA DUBAI AT RAS AL KHOR IN DUBAI	SAMA DUBAI/ CONSULTAIR ENGINEERS & CONSULTANTS/ SYSTEM CONSTRUCT
ABU DHABI INTERNATIONAL AIRPORT EXPANSION - PROPOSED WAREHOUSE PHASE 1A (100 WAREHOUSES)	ADAC/PARSONS INTL./STANLEY-UK/SYSTEM CONSTRUCT.
CONSTRUCTION OF INTERNATIONAL QUALITY STEEL CASTING CO. ON PLOT NO: 598-917 AT DUBAI INVSETMENT PARK, DUBAI	SEMAC CONSULTANTS / BRIDGEWAY & TEEJAN CONTRACTING
TENCATE MIDDLE EAST (PHASE 2) AT TECHNOPARK, DUBAI	TENCATE MIDDLE EAST / MATTEX
WARE HOUSE & OFFICE BUILDING FOR NATIONAL ENGINEERING GROUP ON PLOT MO: S10201, JAFZA	NATIONAL ENGINEERING GROUP / COMFORT HOUSE CONTRACTING
DISTRIBUTION CENTRE FOR GULF AGENCY CENTRE (GAC) CO., AT JEBEL ALI FREE ZONE	PAX KENT INT'L. / DUTCO BALFOUR BEATTY CO

## Our Major Projects in the Middle East

PROJECT	CLIENT/ CONSULTANT / MAIN CONTRACTOR
CONSTRUCTION OF OPTRION MEDIA DISCS AND RELATED APPAREL FACTORY ON PLOT NO: TP010108 AT TECHNO PARK, JEBEL ALI	OPTRION FZE,
MEP WORKS FOR 4 NOS. OF ADNOC FILLING STATIONS AT 1.AL WAGAN ,AL AIN 2. BATHA AL HAYER, AL AIN 3. AL MAQOOM, AL AIN 4. AL KHALEEJ, ABU DHABI	ALI MOOSA & SONS GROUP / DIAR CONSULTANT/ GAZI AWADI
BURJEEL HOSPITAL FOR LIFE LINE ON PLOT NO: 62-SECTOR E-18/03, ABU DHABI , UAE	JAMES L WILLIAMS MIDDLE EAST (JLW) / ARCH. & PLANNING GROUP
CABLE FACTORY FOR POWER PLUS CABLE COMPANY LLC AT FUJAIRAH	FUJSENG / POWER PLUS CABLE
FIRE PROTECTION WORKS FOR AL QUSAIS METRO CAR PARK, BUS STATION AND FOOT BRIDGE AT AL QUSAIS DUBAI	DHABI CONTRACTING / RTA
GOODRICH MRO FACILITY , JABEL ALI FREE ZONE	JAFZA / SCOTT WILSON KIRKPATRICK / AMANA CONTRACTING & STEEL BUILDINGS
FACTORY AND OFFICE BUILDING FOR UNIQUE METAL TECHNOLOGIES	UNIQUE METAL TECHNOLOGIES/ COMFORT HOUSE
CIVIL & RELATED MEP WORKS FOR NESTLE MIDDLE EAST FZE (UTILITY SERVICES FOR NESTLE FOOD & BEVERAGE FACTORY) AT TECHNOPARK, DUBAI	NESTLE MIDDLE EAST FZE
MEP WORKS FOR DJ-176 BOROUGE DISTRIBUTION CENTRE	AMANA / BOROUGE / TEBODIN CONSULTANTS & ENGINEERS
WAREHOUSE,WORKSHOP CUM OFFICE BUILDING ON PLOT NO. S30803 AT JAFZA FOR M/S. LEGNANO TEKNOELECTRIC COMPANY.	TRETT CONSULTING / SEMAC / SYSTEM CONSTRUCT

## Our Major Projects in the Middle East

PROJECT	CLIENT/ CONSULTANT / MAIN CONTRACTOR
G+5 HOSPITAL BUILDING FOR DR. MOOPEN'S GROUP AT SOHAR, OMAN	DR. MOOPEN'S GROUP
NESTLE FOOD & BEVERAGE FACTORY	NESTLE MIDDLE EAST FZE
CIVIL & ELECTROMECHANICAL WORKS FOR MATTEX FACTORY IN TECHNOPARK, JABEL ALI	PAXKENT INTERNATIONAL
LIFE LINE HOSPITAL AT MUSSAFAH, ABU DHABI	LIFE LINE HOSPITAL
PORSCHE SHOWROOM MAINTANANCE AND SERVICE STATION AT MUSSAFAH, ABU DHABI	ALI & SONS / OPTIMA ENGINEERING / SYSTEM CONSTRUCT
PALM JUMEIRAH SHORELINE APARTMENT (PACKAGE 1 7 3)	BIN BELAILA BAYTUR LLC
FIRE FIGHTING WORKS FOR M/S. GOLD & SILVER TOWER FOR DMCC	FAITHFUL & GOULD / KEO / BIN BELAILA BAYLUR LLC
AL GHAIL POWER PLANT	AL GHAIL POWER LLC
FIRE PROTECTION SYSTEM FOR COLD & DRY STORE ON PLOT NO: 598-1092 AT DUBAI INVESTMENT PARK (PHASE 2) FOR GLOBAL SHIPPING & LOGISTICS LLC	GLOBAL SHIPPING & LOGISTICS LLC
WAREHOUSE CUM OFFICE ON PLOT NO. S 30902 FOR M/S REDINGTON GULF FZE, AT JEBEL ALI FREE ZONE, DUBAI	AMANA
WAREHOUSE AND OFFICE BUILDING FOR TRIDENT FREIGHT LLC (RAIS HUSSAIN SAADI GROUP) ON PLOT NO: W-40B AT DAFZA	IAN BANHAM & ASSOCIATES / AL HAWAR
KHALIFA PORT AND INDUSTRIAL ZONE(KPIZ) PROJECT, TAWEELA, ABUDHABI	ADPC/PRIME CONSULTANT/AL MASAOOD BERGUM
SEIMENS CAMP PROJECT, SHUWEIHAT, RUWAIS	SEIMENS / AL MASAOOD BERGUM
POPULATION REGISTRATION IDENTIFICATION CARD PROJECT AT AL BARSHA, DUBAI	MINISTRY OF INTERIOR ABU DHABI POLICE GHQ / MACLEAN CONSTRUCTION

## Our Major Projects in the Middle East

PROJECT	CLIENT/ CONSULTANT / MAIN CONTRACTOR
FIRE PROTECTION SYSTEM FOR FLUORINE COMPLEX (WORKSHOP AND STOCKS BUILDING) AT ABU DHABI FOR GULF FLOUR	DHAFRA INT'L PROJECTS GROUP / NASER NOFAL CONSULTING
MEP RELATED WORKS IN VARIOUS OIL AND GAS FIELD IN DIFFERENT SITES FOR ADVANCE INTEGRATED SYSTEM - ABU DHABI	ADVANCE INTEGRATED SYSTEM
WAREHOUSE & OFFICE BUILDING FOR CROWN EMIRATES AT JAFZA	PAX KENT INT'L / SANDS CONTRACTING
FIRE PROTECTION SYSTEM FOR MOHEBI LOGISTICS (COLD WAREHOUSE & OFFICE) ON PLOT NO: S 50201 TO S50208 AT JAFZA, DUBAI	SEED BUILDING SERVICES / ROSHAN CONSTRUCTION
FIRE PRETECTION SYSTEM FOR EDIBLE OIL FACTORY AT JAFZA, DUBAI	ORION CONSULTANT
AIR CONDITATION AND VENTILATION WORKS FOR COSTRA GROUP ON PLOT NO: 039 AT INTERNATIONAL MEDIA PRODUCTION ZONE	SYSTEM CONSTRUCT
TECHIQE INTERNATIONAL OFFICE, SERVICE BLOCK & FACOTY ON PLOT NO: 10833 IN JAFZA	ORION CONSULTANT / COMFORT HOUSE
ELCOME INTERNATIONAL LLC INDUSTRIAL BUILDING AT DIP	FA BAKER CONSULTANTS / ARC CONSTRUCTION LLC
CIVIL WORKS FOR QUEST VITAMINE (UTILITY SERVICES FOR G+1 PHARMACEUTICAL PLANT) AT JAFZA	SEMAC CONSULTANTS
ENCO FILLING STATION ON PLOT NO: 262-2937 AT AL MISHAR FIRST(MIRDIFF AREA)	CYLINGAS COMPANY / ENOC
FIRE PROTECTION AND HVAC SYSTEM FOR PRODUCTION AREA AEROSAL OF SPRAY PERFUME & OFFICE ON PLOT NO: S40802 AT JAFZA FOR RASASI PERFUMES INDUSTRY LLC	RASASI PERFUMES INDUSTRY LLC / +971 ARCHITECTS

## Our Major Projects in the Middle East

PROJECT	CLIENT/ CONSULTANT / MAIN CONTRACTOR
HVAC & VENTILATION SYSTEM FOR CONTROL ROOM AND BUILDING OF THE NEW 3MIGD SEAWATER R.O PLANT AT KALBA	S.E.W.A
HVAC WORKS FOR FACTORY, WARE HOUSE AND OFFICE BUILDING FOR PRINTPAC ME FZ LLC AT IMPZ,DUBAI	SYSTEM CONSTRUCT
ELECTRICAL WORKS FOR 4 NOS PUMPING STATION AT RAHA BEACH DEVELOPEMENTS, AL RAHA BEACH ABU DHABI	ALDAR PROPERTIES PJSC / MAUNSELL / AECOM /BELHASA PROJECTS
FIRE PROTECTION SYSTEM FOR NATIONAL OIL WELL ON PLOT NO: S- 50601, S-50605 & S- 50607 AT JAFZA,DUBAI, UAE	AL SARAYA ENGINEERING / SYSTEM CONSTRUCT
MARLBORO WAREHOUSE IN SHARJAH FREE ZONE	MARLBORO
CIVIL WORKS FOR SUBSTRUCTURE FOR WAREHOUSE EXTENTION AT JAFZA	UNILEVER
FIRE PROTECTION WORKS FOR CENTRAL FACILITY YARD FOR ARCHIRODON	ARCHIRODON CONSTRUCTION (OVERSEAS) CO.
INTERIOR FIT OUT WORKS IN ROYAL VILLA/ QASAR AL SARB/PAVILLION AT LIWA-ABU DHABI	ALEC
FIRE ALARM, FIRE FIGHTING AND EXIT EMERGENCY LIGHT SYSTEM FOR ABU DHABI PRINTING AND PUBLISHING COMPANY, SHAHAMA	ABU DHABI PRINTING AND PUBLISHING COMPANY / ALBA-TEC CONST. & DEV.
FIRE PROTECTION SYSTEM FOR EMIRATES FINANCIAL TOWER (CAR PARKING) AT DUBAI	ENGG. ASSOCIATES / MAG ROBOTIC SYSTEMS
MC DERMOTT OFFICE BUILDING IN JABEL ALI( G + 2 BUILDING)	DUTCO
FIRE PROTECTION SYSTEM FOR UNILEVER GULF FZE, LIPTON TEA FACTORY AT JEBEL ALI, DUBAI	UNILEVER

## Our Major Projects in the Middle East

PROJECT	CLIENT/ CONSULTANT / MAIN CONTRACTOR
INTERIOR WORKS IN HOTEL ROOMS FOR KOCACHE ENTERPRISES LLC	KOCACHE ENTERPRISES
FIRE PROTECTION SYSTEM FOR SAUDI GERMAN HOSPITAL HOUSING PROJECT AT AL-BARSHA III -DUBAI	INTERNATIONAL HOSPITALS CONSTRUCTION CO. / BKG CONSULTING, GERMANY
CONSTRUCTION OF PUMP ROOM & WATER TANK FOR M/S. UNILEVER FZE	UNILEVER
JUMEIRAH COASTAL ZONE DEVELOPMENT PHASE - 1	DUBAI MUNICIPALITY/ OVERSEAS AST INTERBETON J.V
GULF AGENCY COMPANY AT JABEL ALI FREE ZONE, DUBAI	PAXKENT INTERNATIONAL
FIRE PROTECTION SYSTEM FOR CLARION SIGH LLC ON PLOT NO: 597-823 AT DIP IN DUBAI	SYSTEM CONSTRUCT
FIRE PROTECTION WORKS FOR OFFICE UNITS FOR IMPRIGILLO SPA, ABU DHABI	OFFICE UNITS FOR IMPRIGILLO SPA / AL MASAOOD BERGUM
FM 200 SYSTEM AND SPRINKLER WORK FOR NESTLE MIDDLE EAST	NESTLE

### POWER PLANTS

PROJECT	CLIENT/ CONSULTANT / MAIN CONTRACTOR
HWSS SYSTEM - 220/11KV 10 MVASY	AREVA
THYSSENKRUPP 1X50MWC02	BHEL
CO2 SYSTEM FOR 160 MW STG FOR RVUNLC02	BHEL
CO2 SYSTEM FOR 68 MW STG FOR MRPLC02	BHEL
CO2 SYSTEM FOR 350 MW STG FOR PIPAVAV & HAZIRAC02	BHEL
RITHALA 108MW CCPP - BALANCE OF FIRE FIGHTINGHYDRANT, SPRAY, FDA, INERGEN	NDPL
CO2 - KAKINADA (2 FR5 GTG)C02	BHEL
MAA DURGA 2X30MWHYDRANT, SPRAY, PUMPHOUSE	CETHAR VESSELS
CHP OF 4X250 MW TPP AT RAIGHARHHYDRANT	JSW
COASTAL THERMAL 2X135 MWSPRAY, EXTINGUISHER	THERMAX
PGCIL JATIAKARA 765KVA SUBSTATIONHYDRANT, SPRAY, FDA	AREVA
PGCIL ANPARA 400KVA SUBSTATIONHYDRANT, SPRAY, FDA	AREVA
NTPC AURIYA CLEAN AGENT SYSTEMINERGEN	NTPC
SRAVANTI POWER 2X225MW KASHIPURALL	SRAVANTHI POWER
SHRI CEMENTS 2X150 MWH, SY, A	CETHAR VESSELS
ROSA 2X600 EXPANSIONALL	RELIANCE
GVK 2X275 MW TPP PUNJABHYDRANT, SPRAY, FDA	BINA TPP 2X250 MWALL
2X600 KAWAIALL	ADANI
FFS FOR 6 X150 MW MAHAN CPP AT SINGRAULI - MP	HINDALCO INDUSTRIES MUMBAI
FFS FOR 6 X150 MW CPP OF ADITYA ALUMINIUM PROJECT AT LAPANGA (SAMBALPUR) - ORISSA	HINDALCO INDUSTRIES MUMBAI

## Our Power Plant Project References

### POWER PLANTS

PROJECT	CLIENT/ CONSULTANT / MAIN CONTRACTOR
FFS FOR AL KAMIL POWER PROJECT - OMAN	AL KAMIL POWER CO., SULTANATE OF OMAN.
FFS FOR 6 X 40MW HYDROELECTRIC LOWER JURALA PROJECT.	ALSTOM PROJECTS INDIA LTD.,VADODARA
FPS FOR CHAMERA -III ( 3X77 MW HEPP ) SIKKIM	ALSTOM PROJECTS INDIA LTD.,VADODARA
FPS FOR URI HYDROELECTRIC POWER PROJECT ( 4X60MW HEPP), KASHMIR	ALSTOM PROJECTS INDIA LTD.,VADODARA
CO2 FIRE FIGHTING SYSTEM FOR 2 X FR.5 GT GENERATOR HPCL, VIZAG	ARKAY ENERGY LIMITED, CHENNAI
FFS FOR 1 X 30 MW CCP AT ARYAN COAL BENIFICATION LTD., CHAKABURA DIST. CHHATTISGARH.	ARYAN COAL BENIFICATION LTD,DELHI
FFS FOR 1 X 18 MW CAPTIVE POWER PLANT, JHARSUGUDA, ORISSA.	ARYAN ISPAT & POWER (P) LIMITED, NEW DELHI.
FFS FOR BARKA POWER STATION - PHASE II	ASES BARKA POWER,OMAN./DOOSAN HEAVY INDUSTRIES & CONSTRUCTION, KOREA.
FFS FOR FUEL OIL STORAGE TANK COOLING SYSTEM - BARKA POWER & DESALINATION PLANT - OMAN	ASES BARKA POWER,SULTANATE OF OMAN.
BFPS FOR 1 X 500 MW KAKATHIYA THERMAL POWER PROJECT	BGR ENERGY & ANDHRA PRADESH POWER GENERATION CORPORATION LTD., BHOPPALAPALLI.
FDA SYSTEM FOR 1X500 MW KOTHAGUDEM TPP	BGR ENERGY SYSTEMS LTD., CHENNAI
FPS AT TNEB, VALUTHUR, RAMANATHAPURAM.	BGR ENERGY SYSTEMS LTD., CHENNAI
CO2 SYSTEM FOR 1 X FR-6 GNFC BHARUCH	BHEL
CO2 SYSTEM FOR 2 X FR-6 GGSR BHATINDA	BHEL
CO2 FIRE EXTINGUISHING SYSTEM FOR TATA JOJOBERA	BHEL - HYDERABAD
FPS FOR AL - GAIL UAE RAKIA 2X FR - 6B GTGS	BHEL - HYDERABAD

### POWER PLANTS

PROJECT	CLIENT/ CONSULTANT / MAIN CONTRACTOR
FPS FOR 2X120 MW POWER PLANT BANGALADESH.	BHEL - HYDERABAD
CO2 FLOODING SYSTEM FOR 3 X FR.6 GT & 32 MW TG FR.6 GAS TURBINES	BHEL - HYDERABAD
FFS FOR 2 X 25 MW CPP EXPANSION PROJECT, HPCL- VIZAG.	BHEL - HYDERABAD
CO2 SYSTEM FOR 18.55 X 22.6 MW STG AT EID PARRY.	BHEL, HYDERABAD
CO2 SYSTEM FOR 3XFR. 9E GTG AT MUKHAIZNA I & II, PDO QARN ALAM	BHEL, HYDERABAD
CO2 SYSTEM FOR AIR COOLED TURBO GENERATOR AT DHOLPUR.	BHEL, HYDERABAD
FFS FOR 59 MW (ISO) COMBINED CYCLE POWER PLANT	BHEL, HYDERABAD
LP CO2 FOR (2 X FR-9FA) GSPC PIPAVAV PROJECT	BHEL, HYDERABAD
SUPPLY OF PORTABLE FM-200 EXTINGUISHERS FOR 1 X 15 MW STG, SAIL, BHILAI PROJECT	BHEL, HYDERABAD
CO2 SYSTEM FOR - 120MW JINDAL STAINLESS & JAY PEE REWA CEMENT PROJECTS	BHEL, HYDERABAD
CO2 EQUIPMENT FOR 2X120 MW FOR NALCO	BHEL, HYDERABAD
CO2 EQUIPMENT FOR 18 MW MANGALAM CEMENT.	BHEL, HYDERABAD
CO2 EQUIPMENT FOR 2X120 MW FOR NALCO.	BHEL, HYDERABAD
CO2 FIRE EXTINGUISHING EQUIPMENT FOR 1 X 77 MW GT FOR M/S.BHUSAN STEEL	BHEL, HYDERABAD.
CO2 EQUIPMENT FOR 1X38 MW STG FOR APGCL- LAKWA.	BHEL, HYDERABAD.
HVV SPRAY SYSTEM FOR TRANSFORMERS	BHEL, JHANSI
FFS FOR 30 MW CPP AT MANDIDEEP	BHEL, HARIDWAR

## Our Power Plant Project References

### POWER PLANTS

PROJECT	CLIENT/ CONSULTANT / MAIN CONTRACTOR
CO2 FES FOR AIR COOLED TURBO GENERATOR AT DHOLPUR.	BHEL,HARIDWAR
FFS FOR GTG BASED CPP BRPL - DHDT PROJECT, BONGAIGAON, ASSAM	BHEL-HYDERABAD
FDA FOR 110KV SWITCH YARD, KUTTIYADI	BHEL-ISG BANGALORE
HVW SPRAY SYSTEM FOR 50 MVA TRANSFORMER FOR THE PROJECT - PGCIL BALIPARA 132/33 KV SUBSTATION, ASSAM	BHEL-ISG BANGALORE
CO2 FE EQUIPMENT FOR 33 MW STG FOR INTEGRATED STEEL PLANT AT MERAMANDALI, ORISSA.	BHUSHSAN STEEL & STRIPS LIMITED, NEW DELHI
FFS FOR30 MW CAPTIVE POWER PLANT, BIHAR.	BIHAR CAUSTICS & CHEMICALS LTD., BIHAR.
FFS FOR GTG BASED BRPL - DHDT PROJECT, DHALIGAON, ASSAM	BONGAIGOAN REFINERY & PETROCHEMICALS LTD. (BRPL), ASSAM.
FFS FOR 1X36MW CPP, REI AGRO, GUJARAT	CETHAR VESSELS
FFS FOR1X36 MW POWER PLANT,GANDHIGRAM	CETHAR VESSELS (P) LTD., TIRUCHIRAPPALLI
FFS FOR240 MW SALALAH POWER PRIVATISATION PROJECT - OMAN	DHOFAR POWER CO. S.A.O.G., SALALAH, SULTANATE OF OMAN.L&T ,OMAN
FFS FOR2 X 120 MW PEAKING POWER PLANT - SIDDHIRGANJ - BANGLADESH	ELECTRICITY GENERATION COMPANY OF BANGLADESH.BHEL,HYDERABAD.
FFS FOR CPP AT HPCL, VIZAG.( HYGRADE PELLETS, VISHAKAPATNAM)	ESSAR CONSTRUCTION LTD.
FFS FOR 92.2 MW CAPTIVE POWER PLANT, VALUTHUR	GEA
FFS FOR 445 KW KONASEEMA CCPP	GEA, CHENNAI - 600 018
FFS FOR330 MW GAS BASED CCPP RAJYA VIDYUT UTPADAN VIGAM LTD (RVUNL) DHOLPUR, RAJASTHAN.	GEA, CHENNAI - 600 018.

### POWER PLANTS

PROJECT	CLIENT/ CONSULTANT / MAIN CONTRACTOR
FFS FOR 220 MW TANIR BAVI POWER PLANT, MANGALORE.	GMR POWER CORPORATION PVT. LTD., BANGALORE
FFS FOR 200 MW DIESEL POWER PLANT, BASIN BRIDGE, CHENNAI.	GMR POWER CORPORATION PVT. LTD., BANGALORE.
CONVERSION OF HALON BASED FIRE PROTECTION SYSTEM WITH CO2 FLOODING SYSTEM FOR 3 X FR.6 GT, GTG & 1X50MW STG AT 145MW CCPP PROJECT AT GIPCL	GUJARAT INDUSTRIES POWER CO. LTD., BARODA
FFS FOR 2 X 600 MW HISAR THERMAL POWER PROJECT - HISAR - HARYANA	HARYANA POWER GENERATION CORPORATION LTD., HARYANA.
FFS FOR 1 X 110 MW PANIPAT THERMAL POWER STATION	HARYANA POWER GENERATION CORPORATION LTD., HARYANA.
FFS FOR 2 X 300 MW DCR THERMAL POWER PROJECT, YAMUNA NAGAR, HARYANA.	HARYANA POWER GENERATION CORPORATION LTD., HARYANA.
CO2 FIRE EXTINGUISHING EQUIPMENT FOR 4 X 76 MW, MANERI BHALI HEP STAGE-II	HINDUSTAN ELECTRO GRAPHITES LTD, CHENNAI
FFS FOR 2 X 25 MW CO-GENERATION POWER PLANT, HPCL - VIZAG REFINERY,	HINDUSTAN PETROLEUM CORPORATION LIMITED, VIZAG
FPS FOR ADDITIONAL SEA WATER APPLICATION PROJECT	HINDUSTAN PETROLEUM CORPORATION LIMITED, VIZAG
FFS FOR 1 X 80 MW CAPTIVE POWER PLANT, HZL ZAWAR MINES, RAJASTHAN.	HINDUSTAN ZINC LIMITED, RAJASTHAN.
FFS FOR 30 MW CAPTIVE POWER PLANT, VIZAG.	HY-GRADE PELLETS LIMITED, VIZAG.
INDIAN OIL CORPORATION LIMITED, DIGBOI.	FPS FOR GT PROJECT, IOCL - DIGBOI REFINERY
EMULSIFIER SYSTEM FOR 8 NOS. OF TRANSFORMERS	INDIAN OIL CORPORATION LIMITED, HALDIA.
FPS FOR GT PROJECT, IOCL - HALDIA REFINERY	INDIAN OIL CORPORATION LIMITED, HALDIA.
FFS FOR 2 X 125 MW POWER PLANT, DUBURI, ORISSA.	JINDAL STAINLESS LTD., BHUBANESHWAR.

## Our Power Plant Project References

### POWER PLANTS

PROJECT	CLIENT/ CONSULTANT / MAIN CONTRACTOR
CO2 FIRE EXTINGUISHING SYSTEM FOR 60 MW STG FOR M/S.CESE-CALCUTTA.	JINDAL STAINLESS LTD., GURGAON, HARYANA
FIRE PROTECTION SYSTEM FOR 2X30 MW CCP AT SISCOL, SALEM.	JINDAL STEEL
CO2 & FM200 SYSTEM FOR BHAVINI, KALPAKKAM PROJECT	KIRLOSKAR BROTHERS LIMITED, PUNE
FFS FOR 445 MW KONASEEMA COMBINED CYCLE POWER PROJECT, KONASEEMA.	KONASEEMA GAS POWER LIMITED, HYDERABAD.
FFS FOR 2 X 22.3 MW CAPTIVE POWER PLANT, BCL, RAJASTHAN.	KONASEEMA GAS POWER LIMITED. KHAIRATABAD, HYDERABAD - 500 004.
FFS FOR 2 X 300 MW LANCO AMARKANTAK THERMAL POWER STATION, KORBA, CHHATTISGARH	LANCO AMARKANTAK POWER (P) LTD., HYDERABAD.
FFS FOR 368 MW GAS BASED COMBINED CYCLE POWER PLANT, KONDAPALLI, ANDHRA PRADESH.	LANCO KONDAPALLI POWER PRIVATE LTD., HYDERABAD
FFS FOR 30 MW CAPTIVE POWER PLANT, METTUR.	MALCO
FFS FOR MAWELAH & IBRI SUBSTATION - OMAN	MINISTRY OF ELECTRICITY & WATER, SULTANATE OF OMAN.
FFS FOR 2 X 210 MW THERMAL POWER STATION, NEYVELI.	NEYVELI LIGNITE CORPORATION LTD., NEYVELI.
FFS FOR PDO - QARN ALAM - 2 X FR.9E FA GT PROJECT	PETROLEUM DEVELOPMENT OMAN, SULTANATE OF OMAN
FFS FOR PDO - QARN ALAM - 3 X FR.9E FA GT PROJECT	PETROLEUM DEVELOPMENT OMAN, SULTANATE OF OMAN./BHEL, HYDERABAD.
FFS FOR PDO - QARN ALAM - 3 X FR.9E FA GT PROJECT	PETROLEUM DEVELOPMENT OMAN, SULTANATE OF OMAN./BHEL, HYDERABAD.
FFS FOR 3 X 110 MW GAS BASED COMBINED CYCLE POWER PLANT, DHOLPUR, RAJASTHAN	RAJASTHAN RAJYA VIDYUT UTPADAN NIGAM LTD. (RRVUNL), RAJASTHAN.

### POWER PLANTS

PROJECT	CLIENT/ CONSULTANT / MAIN CONTRACTOR
FFS FOR1 X 36 MW CAPTIVE POWER PLANT, GANDHIDHAM, GUJARAT.	REI AGRO LIMITED, GUJARAT.
FFS FOR2 X 300 MW ROSA THERMAL POWER PROJECT - STAGE I - SHAJAHANPUR, U.P.	RELIANCE ENERGY LIMITED, MUMBAI.
FFS FOR 2X600MW HISAR TPP	RELIANCE ENERGY LTD.
FIRE PROTECTION SYSTEM FOR 2 X 300 MW DCRTTP AT YAMUNA NAGAR, HARYANA.	RELIANCE ENERGY LTD.MUMBAI
CO2 EQUIPMENT FOR 1X38 MW STG FOR APGCL-LAKWA	RELIANCE ENERGY LTD.MUMBAI
SUPPLY OF PORTABLE FM-200 EXTINGUISHERS FOR 1 X 15 MW STG	SAIL, BHILAI PROJECT/BHEL, HYDERABAD
FFS FOR1000 MW COMBINED CYCLE POWER PLANT	SOHAR ALUMINIUM, SOHAR, SULTANATE OF OMAN./ALSTOM TURBO POWER SYSTEMS, FRANCE.
SONGO SONGO GAS DEVELOPMENT & POWER GENERATION PROJECT, TANZANIA.	SONGAS LIMITED,DAR ES SALAAM, TANZANIA./ LARSEN & TOUBRO LIMITED,OGSP,MUMBAI
FFS FOR101 MW COMBINED CYCLE POWER PLANT, KUTTALAM.	TAMIL NADU ELECTRICITY BOARD (TNEB), CHENNAI.
FFS FOR107 MW COMBINED CYCLE POWER PLANT, KOVILKALAPPAL.	TAMIL NADU ELECTRICITY BOARD (TNEB), CHENNAI.
FFS FOR100 MW COMBINED CYCLE POWER PROJECT, PHASE II, VALUTHUR, TAMILNADU.	TAMIL NADU ELECTRICITY BOARD (TNEB), VALUTHUR.
FFS FOR 1X80 MW CPP FOR HZL, ZAWAR MINES, UDAIPUR, RAJASTHAN.	TATA PROJECTS LTD.HYDERABAD.
FFS FOR1 X 30 MW CAPTIVE POWER PLANT,MAITHAN ISPAT LIMITED	THE INDURE PRIVATE LIMITED, NEW DELHI.
FFS FOR2 X 15 MW CAPTIVE POWER PLANT, INDORAMA PETROCHEMICALS LTD.	THE INDURE PRIVATE LIMITED, NEW DELHI.
CO2 FIRE EXTINGUISHING EQUIPMENT FOR 125 MW STG FOR M/S.RVUNL-GIRAL.	THE INDURE PVT. LTD., DELHI

## Our Power Plant Project References

### POWER PLANTS

PROJECT	CLIENT/ CONSULTANT / MAIN CONTRACTOR
FPS FOR 2X12 MW CPP AT MAHESWARI ISPAT LTD. KHUNTURI, ORISSA.	THE INDURE PVT. LTD., DELHI
CO2 FIRE FIGHTING SYSTEM FOR 3 X 25 MW STG FOR M/S. JSPL, RAIGARH.	THE INDURE PVT. LTD., DELHI
FPS FOR 1X30 MW CPP AT MAHESWARI ISPAT LTD. DUBURI, ORISSA.	THE INDURE PVT. LTD., DELHI
FPS FOR 2X500 TPD VERTICAL SHAFT KILNS AT RINL VIZAG	VULCAN ENGINEERING
QURM GRID SUBSTATION	GALFAR
MATTRAH GRID SUBSTATION	GALFAR

### NUCLEAR POWER PLANTS

PROJECT	CLIENT/ CONSULTANT / MAIN CONTRACTOR
MICROPROCESSOR BASED INTELLIGENT ADDRESSABLE ANALOG FIRE ALARM SYSTEM FOR 500 MWE PROTOTYPE FAST BREEDER REACTOR (PBFR) BHAVINI, KALPAKKAM.	BHAVINI KALPAKKAM
EMULSIFIER SYSTEM FOR TRANSFORMERS	IGCAR KALPAKKAM

### OIL & GAS

PROJECT	CLIENT/ CONSULTANT / MAIN CONTRACTOR
LP CO2 SYSTEM FOR GSPC PIPAVAV PROJECT	BHEL - HYDERABAD
CO2 SYSTEM FOR IER, DUBAI	BHEL - HYDERABAD
CO2 SYSTEM FOR BONGAIGAON REFINERY	BHEL - HYDERABAD
FFS AT HPCL, VIZAG	BHEL - HYDERABAD
FPS FOR SEA WATER APPLICATION PERTAINING TO HPCL, VIZAG.	BHEL - HYDERABAD
CO2 SYSTEM FOR IOCL-HALDIA	BHEL - HYDERABAD
FFS FOR FUEL BUNKERING FACILITIES - SALALAH PORT - OMAN	BRITISH PETROLEUM, SULTANATE OF OMAN./ FUJAIRAH MARINE SERVICES, OMAN
ESSAR RANIGANJHYDRANT, FDA	ESSAR
CPCL 1X20MW GTGALL	BHEL
ONGC TRIPURA LP CO2	BHEL
GPEL CO2 UPGRADINGCO2	GPEL
HALLIBURTON KAKINADAFDA	EAST COAST
ENNORE TERMINAL FOAM SYSTEMFOAM	HPCL
DV FOR MRPL DHDH PROJECTSHYDRANT, SPRAY	L&T
MRPL EXTENSIONHYDRANT	L&T
ONGC D1 DEVELOPMENT PROJECT DCP	ESSAR
PRAXAIR IOCL PARADEEPHYDRANT, SPRAY, INERGEN	UHDE
BCPL LAPATEKATAHYDRANT, SPRAY, FDA, INERGEN	BHEL
MHNPP & MHNMLQ DCP SKIDSDCP	L&T
HPCL LOBS LONG RANGE MONITORSM	L&T
ONGC DCP SKIDSDCP	L&T
LNG TERMINAL FDA	CINDA

## Our Oil & Gas Project References

### OIL & GAS

PROJECT	CLIENT/ CONSULTANT / MAIN CONTRACTOR
FFS FOR CPCL - MANALI REFINERY	CHENNAI PETROLEUM CORPORATION LIMITED
SUPPLY OF FIRE HYDRANT COMPONENTS FOR ONGC, RAJAMUNDRY	CLOUGH ENGINEERING LTD., AUSTRALIA
INERGEN SYSTEM FOR IOCL - PANIPET	ENGINEERS INDIA LIMITED, NEW DELHI.
SUPPLY OF MONITORS FOR VADINAR REFINERY EXPANSION	ESSAR OIL LIMITED
CO2 FOR HVJ COMPRESSOR SYSTEM & LPG PLANT.	GAIL (INDIA) LTD. GUNA, VIJAIPUR.
REPLACEMENT OF HALON SYSTEM WITH PLC BASED CO2 SYSTEM	GAIL (INDIA) LTD., VIJAIPUR
CO2 FLOODING SYSTEM FOR GTC & GTG OF HAZIRA	GAIL INDIA LTD., HAZIRA - SURAT
FPS FOR HYDROTREATER PROJECT (LSTK - 1), IOCL - GUWAHATI	INDIAN OIL CORPORATION LIMITED, GUWAHATI.
FPS FOR IOCL - HALDIA REFINERY EXPANSION PHASE - II	INDIAN OIL CORPORATION LIMITED, HALDIA.
LPG BOTTLING PLANT, MADURAI.	INDIAN OIL CORPORATION LIMITED, MADURAI.
MAINTAANANCE OF GTS 1,2,3,4&5 CO2 SYSTEM OF PANIPAT REFINARY.	INDIAN OIL CORPORATION LIMITED, PANIPAT REFINERY.
LPG BOTTLING PLANT, TIRCHIRAPPALLI	INDIAN OIL CORPORATION LIMITED, TIRCHIRAPPALLI.
FIRE PROTECTION WORKS AT IOCL, VADADORA, GUJARAT	INDIAN OIL CORPORATION VADADORA
FFS FOR IOCL, MANALI & MEENAMBAKKAM	IOCL
FFS FOR IOCL FARIDABAD	IOCL FARIDABAD
FFS GUJARAT REFINERY	IOCL GUJARAT REFINERIES
FLUORO-KEYTONE BASED FIRE SAFETY SYSTEM FOR IOCL R&D CENTRE, FARIDABAD	IOCL, FARIDABAD.
CLEAN AGENT SYSTEM FOR PX-1 PROJECT	IOCL, PANIPAT

### OIL & GAS

PROJECT	CLIENT/ CONSULTANT / MAIN CONTRACTOR
FFS FOR MSQ IMPROVEMENT PROJECT AT DHALIGOEN BRPL,ASSAM	IOCL, ASSAM
FPS FOR DABHOL TERMINAL STATION FOR PART B OF POWER DABHOL PIPELINE	KALPATARU POWER TRANSMISSION LTD.
FFS FOR KRL - DHDS PROJECT	KOCHI REFINERIES LIMITED, KOCHI.
FPS FOR 25 KV ADG SET - 4 NOS FOR CAIRN ENERGY - BARMER SALAY PIPELINE PROJECT	LARSEN & TOUBRO LIMITED, CHENNAI
DCP SKID FOR OFFSHORE MHSRP -PHASE - II PROJECT ONGC	LARSEN & TURBO VALDEL ENGINEERING LTD.
FIRE PROTECTION SYSTEMS IN OIL JETTY	MAURITIUS PORT AUTHORITY,AFCONS INFRASTRUCTURE
FFS FOR OIL STORAGE & TERMINAL FACILITY -SOHAR PORT - OMAN	OIL TANKING ODFJELL TERMINALS & CO. LLC, OMAN./INDIAN OIL TANKING ECS LLC. OMAN.
FFS FOR UNLEADED GASOLINE FACILITIES FOR OMAN REFINERY - OMAN	OMAN REFINERY, SULTANATE OF OMAN.
FFS FOR IMPACT PROJECT, MANALI.	PETRO ARALDITE PVT. LTD., CHENNAI.
FOAM SKID & FOAM CHAMBER FOR LEKHWAIR PRODUCTION STATION.	PETROLEUM DEVELOPMENT OMAN, SULTANATE OF OMAN./OMAN REFINERY, OMAN
MVWS FOR CPCL, CHENNAI	PETRON ENGINEERING CONSTRUCTION LIMITED
IG 100 SYSTEM FOR BHARUNI REFINERY	PUNJ LOYD
CO-GENERATION PROJECT, RIL - JAMNAGAR REFINERY.	RELIANCE INDUSTRIES LIMITED, JAMNAGAR.
FFS FOR TWO HEATERS PLANT, MANALI,CHENNAI	TAMILNADU PETROPRODUCTS LIMITED, MANALI, CHENNAI.
FIRE HYDRANT SYSTEM EXTN FOR NEW HOT OIL HEATER & NEW PACOL CHARGE HEATER	TAMILNADU PETROPRODUCTS LTD,
WATER SPRAY SYSTEM FOR STORAGE TANK & TERMINAL FACILITIES, OMAN (PHASE 6)	OIL TANKING ODFJELL TERMINALS & CO. LLC, OMAN.

## Our Oil & Gas & Process Industries Project References

PROJECT	CLIENT/ CONSULTANT / MAIN CONTRACTOR
DESIGN & ENGINEERING OF HYDRANT SYSTEM, FOAM SYSTEM AND 1WATER SPRAY SYSTEM MARMUL CENTRAL DEVELOPMENT PH-III	PETROLEUM DEVELOPMENT OMAN

### CEMENT

PROJECT	CLIENT/ CONSULTANT / MAIN CONTRACTOR
CO2 EQUIPMENT FOR 18 MW MANGALAM CEMENT.	BINANI CEMENT LIMITED, RAJASTHAN.
FFS FOR LAFARGE SURMA CEMENT CO., CHHATAK, BANGLADESH	LAFARGE / LARSEN & TOUBRO LIMITED, MUMBAI.
FFS FDA IPAS FOR BHARATHI CEMENTS AT KADAPPAH	BHARATHI CEMENTS
FFS FDA IPAS FOR ITALCEMENTI CEMENTS AT KADAPPAH	ITALCEMENTI(ZUARI)
ZUARI FDA	ABB
JSW NANDIAL FDA	JSW
ICL THYSENKRUP TIRUNELVELIAL	THYSENKRUP

### STEEL

PROJECT	CLIENT/ CONSULTANT / MAIN CONTRACTOR
RSP CCTV	SMS SEIMAG
PKG 23A: CENTRALISED COMPRESSED AIR STATIONHYDRANT	BLUESTAR
VSP 1069H, A	AIR LIQUIDE
COAL HANDLING PLANT OF CPP & IPP, JHARSIGUDAH	MCNALLY BHARAT

### INDUSTRIAL

PROJECT	CLIENT/ CONSULTANT / MAIN CONTRACTOR
VSP 71FDA	COSMIC POWER
ISP PACKAGE 22: INTERPLANT CABLE TUNNEL & LBDS BUILDING SPRAYSPRAY	SECURETECH ENTERPRISES
ISP PACKAGE 22: INTERPLANT CABLE TUNNEL & LBDS BUILDINGFDA	SECURETECH ENTERPRISES
NINL DUBRI, ORISSA [CONTINUOUS COSTING CASTING SHOP]FDA	MECON
RSP STOCK HOUSEALL	MCNALLY BHARAT
CCM-1,2,3 OF VSPI	M&P
RSP PACKAGE 90: OBBPALL	SHAPOORJI PALONJI
FDA FOR BLAST FURNACE PACKAGE -IISCO STEEL PLANT	ABB - BANGALORE
FFS FOR LBSS-1&LBSS-4 A/C SALEM STEEL	AREVA T&D INDIA LIMITED
FPS FOR SAIL (BHILAI STEEL PLANT) PROJECT	AREVA T&D INDIA LIMITED
FFS FOR IISCO BURNPUR, POWER BLOWING STATION	BHEL, HYDERABAD
FFS FOR COAL-AND-COKE (01-B) PACKAGE SAIL-IISCO, BURNPUR.	L&T, CHENNAI
FFS FOR BASEMIX (01-C) PACKAGE SAIL-IISCO, BURNPUR.	L&T, CHENNAI
FPS FOR IISCO SINTER PLANT - 2 X 204 SQ.M	LARSEN & TOUBRO LIMITED KOLKATTA
CO2 SYSTEM FOR VSP, VIZAG.	M&P,POWER
FFS FOR BLAST FURNACE PACKAGE - IISCO STEEL PLANT	NCC, HYDERABAD
AUTOMATIC WATER SPRAY SYSTEM FOR (DRENCHER) ELECTRICAL BASEMENT OF COKE OVEN BATTERY NO.4	RASHTRIYA ISPAT NIGAM LTD., VIZHAKAPATNAM
FFS FOR SPECIAL BAR MILL FOR VIZAG STEEL PLANT	SHRIRAM EPC

## Our Process Industries Project References

### INDUSTRIAL

PROJECT	CLIENT/ CONSULTANT / MAIN CONTRACTOR
CO2 FLOODING SYSTEM FOR QUENCH PRESS 1&2 AND SECONDARY QUENCH TANK , KANCHIPURAM	TIMKEN INDIA MANUFACTURING PVT. LTD.,CHENNAI
FDAS FOR VSP - WRM2 PROJECT	VA TECH WABAG LTD., CHENNAI.
FFS FOR WATER TREATMENT FACILITIES AT WIRE ROD MILL, VIZAG	VA TECH, WABAG
MICROPROCESSOR BASED ANALOGUE ADDRESSABLE TYPE FDAS FOR COKE OVEN BATTERY -NO.4 AT VIZAG.	VISAKHAPATNAM STEEL PLANT, VIZAG
DRENCHER SPRAY SYSTEM FOR COB-4	VISAKHAPATNAM STEEL PLANT, VIZAG

### FERTILIZERS & CHEMICAL INDUSTRY

PROJECT	CLIENT/ CONSULTANT / MAIN CONTRACTOR
DVS FOR DIVIS LAB	DIVIS LAB
SPRINKLER SYSTEM	ROHINI INDUSTRIAL ELECTRICALS LTD-KPCL
BASF MANGALORE HYDRANT	BASF
ALSTOM BEARING FACTORY, BARODA HYDRANT, FDA	ALSTOM
LG RANJANGAON PLANT - RAW MATERIAL & FG HYDRANT, SPRINKLER	LG
LOREAL EXPANSIONHYDRANT, SPRINKLER, FDA	LOREAL
ONCOLOGY LABALL	FRESENIUS KABI
LG RANJANGAON PLANTHYDRANT, SPRINKLER	LG
VEDANTA - ALUMINIUM EXPANSION PLANT, BALCO KORBAALL	BALCO
NIPROHYDRANT, SPRINKLER, FDA	SHIMZU

### INDUSTRIAL

PROJECT	CLIENT/ CONSULTANT / MAIN CONTRACTOR
FFS FOR NFCL - CHEMICAL PLANT	NAGARJUNA FERTILIZERS & CHEMICALS LTD., KAKINADA.
FFS FOR ST.GOBAIN H2 PLANT	PRAXAIR
HYDRANT SYSTEM FOR ST. GOBAIN - AIR SEPARATION PLANT	PRAXAIR
FFS FOR NYLON 6.6 TYRE CORD PLANT	THAPAR DUPONT INDIA LTD., CHENNAI.
FFS FOR 2X20V34 SG-CHEMPLAST EXTENSION AT KARAİKAL	CHEMPLAST/WARTSILA INDIA LTD, MUMBAI.
HYDRANT, MVWS & EXTINGUISHER SYSTEM FOR POLYESTER INDUSTRIAL YARN, GUMMIDIPOONDI PROJECT.	SRF LIMITED,GUMMIDIPOONDI.
MV SPRAY SYSTEM FOR LPG BULLETS	SRF LIMITED, GUMMIDIPOONDI
FFS FOR PTA PLANT - HALDIA	MITSUBISHI HEAVY INDUSTRIES LIMITED, CALCUTTA.
FDA SYSTEM FOR VEDANTA ALUMINA FACTORY AT LANJIGARH, ORISSA	VEDANTA/FFE MINERALS PVT. LTD., CHENNAI
SAPPHIRE SYSTEM FOR DATA CENTRE	DIEBOLD ,THANE
CO2 SYSTEM FOR ZINC CONCENTRATOR EXPANSION PROJECT OF HZL.	HINDUSTAN ZINC LIMITED/BATEMAN ENGINEERING( INDIA ) PVT. LTD, BANGALORE.
FFS FOR BALDA MOTHERSON SOLUTION INDIA LTD.	BALDA MOTHERSON SOLUTION INDIA LTD.
AVALON TECHNOLOGIES PVT. LTD., CHENNAI.	AVALON TECHNOLOGIES PVT. LTD., CHENNAI.
FFS FOR 875 TPD OXYGEN PLANT AT TISCO, JAMSHEDPUR.	PRAXAIR INDIS PVT. LTD,

## Our Commercial Project References

### COMMERCIAL

PROJECT	CLIENT/ CONSULTANT / MAIN CONTRACTOR
SAPPHIRE SYSTEM FOR ATC TOWER OF BANGALORE INTERNATIONAL AIRPORT PROJECT.	BANGALORE INTERNATIONAL AIRPORT LIMITED / L&T
GMR HOSPITALITY DISTRICT, H, SPRAY SYSTEM	GMR/ IGI AIRPORT DELHI -DIAL
SERENE SEZ AIROLISPRINKLER	SYNTEL
IMFA FFSHYDRANT	TCS GANDHINAGARHYDRANT, SPRINKLER, SAPPHIRE
FFS FOR ABS BUILDING DIAL	DELHI INTERNATIONAL AIRPORT
TCS - PUNEH, SP	TCS
SAPPHIRE SYSTEM FOR DATA CENTRE AT BANGALORE INTERNATIONAL AIRPORT LIMITED	BANGALORE INTERNATIONAL AIRPORT LIMITED L&T
FFS FOR F-16 FACILITIES AT THUMRAIT AIR BASE - OMAN.	MINISTRY OF DEFENCE, SULTANATE OF OMAN./ LARSEN & TOUBRO LIMITED, OMAN
UPGRADING & REFURBISHMENT OF FIRE PROTECTION SYSTEM - SALALAH PORT - OMAN	MINISTRY OF TRANSPORT & COMMUNICATION, SULTANATE OF OMAN.
FFS FOR SUPER SPECIALITY BLOCK.	BANGALORE MEDICAL COLLEGE.
FAS FOR ITC CHOLA HOTEL ,CHENNAI	ITC GRAND CHOLA THROUGH L&T
FFS FOR OFFICE BUILDING, HITEC CITY-2 PROJECT, GACHIBOWLI, HYDERABAD.	L&T PHOENIX INFOPARKS PVT. LTD., HYDERABAD.
PALM GALLERIA MALL FAS &FFS	LAVINA ESTATES PVT. LTD.
FAS FOR MALL «O» - SHOPPING COMPLEX, EDAPALLY, COCHIN.	OBERON MALL COCHIN
FIRE DETECTION & ALARM SYSTEM FOR SATHYAM OFFICE BUIDING.	SATHYAM COMPUTERS SERVICES LTD., CHENNAI
SHRIRAM - THE GATEWAY - BLOCK A1, PERUNGALUTHUR, CHENNAI.	SHRIRAM PROPERTIES AND INFRASTRUCTURE PVT. LTD., CHENNAI. & B. L. KASHYAP & SONS LIMITED, BANGALORE.

### COMMERCIAL

PROJECT	CLIENT/ CONSULTANT / MAIN CONTRACTOR
INERGEN SYSTEM - DATA CENTRE - CTS - KOLKATA IT PARK - SEZ - KOLKATA (SCHNEIDER ELECTRIC INDIA PVT. LTD)	COGNIZANT TECHNOLOGY SOLUTION (I) PVT. LTD., KOLKATA.
FM 200, CLEAN AGENT SYSTEM, FIRE SUPPRESSION SYSTEM FOR CELLULAR CONTROL ROOM	TATA TELESERVICES LIMITED, HYDERABAD.
FPS FOR BLOCK -1 IITM - RESEARCH PARK,CHENNAI.	IITM - RESEARCH PARK,CHENNAI.
FFS FOR FACTORY AND HUB FACILITY FOR NOKIA SIEMENS NETWORKS,ORAGADAM,CHENNAI.	NOKIA/STERLING AND WILSON PRIVATE LIMITED.
FIRE FIGHTING WORK FOR RESIDENTIAL TOWERS.	LANCO HILLS TECHNOLOGY PARK PVT. LIMITED HYDERABAD
SUPPLY, INSTALLATION, TESTING AND COMMISSIONING OF CCTV SYSTEM NISSAN SHOW ROOM AT AL QURUM	SUHAIL BAHWAN AUTOMOBILES LLC

## Letter of Appreciation from GS E&C

 **GS Engineering & Construction**

Sohar 2 IPP Project (100390)  
P.O. Box 218, Postal Code 322  
Sohar, Sultanate of Oman

جی. ایس. انجنیرنگ اینڈ کونسلٹرنگ  
مشروع صحرای ای پی پی (100390)  
صحرای، 218، صحرای، قریب 322  
منطقه صحرای



### CERTIFICATION

#### TO WHOM IT MAY CONCERN:

*This is to certify that AGNICE INTERNATIONAL and partners is working as Fire Fighting System Subcontractor in our Sohar II Independent Power Plant – Sohar.*

*We found their engineering skills, workmanship and support to be very professional and would be happy to recommend Agnice International*

*Issued on 06<sup>th</sup> day of March 2012 here in Sohar, Sultanate of Oman.*

  
**MR. JUTAE BAE**  
Deputy Site Manager



ERAM GROUP

## Performance Certificate from Flour Daniel

 **Thapar DuPont Limited**

Plot No X1  
SPCDT Industrial Complex  
Gummidipoondi 601 201  
Phone : (91-4119) 23-050/51/52/53  
Fax : (91-4119) 22-718

**TO WHOM IT MAY CONCERN :**

### **Performance Certificate**

This is to certify that Agni Heavy Engineering Industries Ltd., have satisfactorily installed and commissioned a fire protection system, consisting of hydrants; distribution piping; sprinklers; pumps (electric & diesel) with controls; an addressable fire alarm system ; and portable extinguishers, against our Purchase Order No 0771.0116 dated 2/12/96. The work was completed in November '97 at a value of Rs.2,94,36,547.

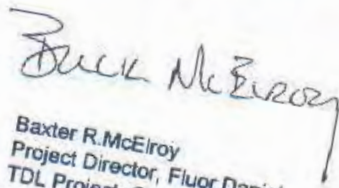

Baxter R. McElroy  
Project Director, Fluor Daniel  
TDL Project, Gummidipoondi.

Registered Office: Plot No. K1 SPCDT Industrial Complex, Gummidipoondi 601 201

## Completion Certificate from Hyundai Heavy Industries Co. Ltd.



29<sup>th</sup> June '99

### WORK COMPLETION CERTIFICATE

This is to confirm that M/s. Agni Heavy Engineering Industries Ltd., Chennai have Designed, supplied, Erected, Tested and Commissioned the entire Fire Protection System consisting of Fire Pumps, Hydrant Network, High Velocity Watery Spray System, Medium Velocity Water Spray System, Foam System, CO<sub>2</sub> Extinguishing System, Fire Alarm System, Portable Extinguishers, Cable Coating and Fire Stop Materials at GMR Vasavi Power Corporation Pvt. Ltd., 200MW Diesel Power Plant. This work was carried out against our Contract Nos. GMR-RP-16, GMR-LCC-1 & P.O for Fire Stop Materials. The work was completed in Sep '98 at a value of Rs.2,09,75,090/- The System is working satisfactorily.

J. G. KIM   
29/06/99  
for HYUNDAI HEAVY INDUSTRIES CO. LTD.



## Completion Certificate from DURR for Hyundai Motor India Paint Shop Facility



Durr India Private Limited,  
#5, Cenotaph Road,  
"Srinivas Towers", II Floor,  
Teynampet, CHENNAI - 600 018  
Tamil Nadu - INDIA.  
Phone : (91) 44 439316-03  
Fax : (91) 44 2432 3622  
Mobile 0091 99401 52073

Dear Sir,

This is to certify that M/s. Agnice Fire Protection Ltd., Chennai has Designed, Supplied, Installed, Tested and Commissioned successfully the Fire Detection and Alarm System, CO2 System, Medium Velocity and Sprinkler System for Paint Shop of Phase II at Hyundai Motor India, Sriperumbudur, Chennai for a value of Rs.2,17,17,272.00 (Rupees Two Crores Seventeen Lakhs Seventeen Thousand Two Hundred and Seventy Two Only)

The system consists of CO2 System, Fire Alarm and Sprinkler System and the systems are working satisfactorily since 5<sup>th</sup> October 2007.

For Durr India Pvt. Ltd.



S.P. Austin  
Senior Project Manager



# Completion Certificate from Reliance Energy India

**RELIANCE Energy**  
Anil Dhirubhai Ambani Group

Reliance Infrastructure Limited  
Deen Bandhu Chhotu Ram  
Thermal Power Project  
2 x 300 MW  
Yamuna Nagar - 125101  
Haryana  
Ph: 01732 321484, 322351  
322636  
Fax: 01732 300010  
www.relianceinfra.com

DEC 19, 2008

### TO WHOMSOEVER IT MAY CONCERN

This is to certify that M/s. Agnic Fire Protection Ltd, Chennai, has Designed, Supplied, Erected, Tested and Commissioned Fire Protection System for our 2 x 300 MW Deen Bandhu Chhotu Ram Thermal Power Plant at Yamuna Nagar, Haryana, at a contract value of Rs. 10,42,87,200 (Rupees Ten Crores Forty Two Lakhs Eighty Seven Thousand Two Hundred Only) awarded vide our Supply P.O No. MSM/23009486 Dt. 12/10/07 Rev.05 and Erection W.O No. MSM/23504342 Dt. 09/06/06.

The Fire Protection system consists of the following:

- Fire Water Pump House
- Fire Hydrant System
- High Velocity Water Spray System
- Medium Velocity Water Spray System
- Foam System
- Inert Gas System
- Fire Detection and Alarm System
- Portable Fire Extinguishers

The above systems are working satisfactorily.

For RELIANCE INFRASTRUCTURE LTD.

*Michael*  
Chief Construction Manager

*Bachittar Singh*  
Bachittar Singh 19-12-2008

## Completion Certificate from Mitsubishi Heavy Industries

  
**MITSUBISHI HEAVY INDUSTRIES LTD. DP PROJECT SITE OFFICE**  
HALDIA MOUZA - BUNIARAICHAK, J.L. NO. 122, MIDNAPORE, WEST BENGAL - 721 002, INDIA  
TEL. : 91-(03224) 75323/4/7, FAX : 91-(03224) 75359

**To: AGNI HEAVY ENGINEERING INDUSTRIES LTD.**  
**ATTN: MR. D. SARAVANAKUMAR**

Date : 07.12.99  
Our ref : MHS/AGNI-E-003

FROM :   
N. Kobori, Project Manager  
DP Project site office

ELECTRICAL   
Mr. H.KAMBE

**Sub:-DP India/FIRE ALARM SYSTEM**

Ref. WORK COMPLETION CERTIFICATE OF FIRE ALARM SYSTEM TESTING AND  
COMMISSIONING.

This is to confirm that M/S AGNI HEAVY ENGINEERING INDUSTRIES LTD. Chennai have supplied the complete fire alarm system and carried out the testing & commissioning job ( from 14th Nov'99 to 7th Dec'99 , 24 days ) for the same of our PTA plant at Haldia.

The [commissioning] work for Fire alarm system was completed on 7<sup>th</sup> Dec'99. The system is working satisfactory. However incase of any future problem in the system , MHI shall take necessary assistance from M/s Agni Heavy Industries.

Best regards,



# Completion Certificate from Saint-Gobain



19.04.01

## TO WHOMSOEVER IT MAY CONCERN

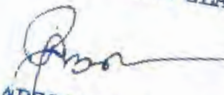

This is to certify that M/s. AGNICE FIRE PROTECTION LTD., (Formerly M/s.AGNI HEAVY ENGINEERING LTD.,) Chennai, have satisfactorily installed and commissioned NOTIFIER, USA, make addressable Fire Detection & Alarm System at our premises at Saint-Gobain Glass India Ltd., Sriperumbudur. This order consisted of one number of 4-loop addressable fire alarm panel with monitor and printer, one number of repeater panel and 439 devices (comprising of detectors, hooters, call points and short circuit isolators). The above work was carried out vide P.O.No.HF-907003 and HF-907004 dated 01.07.1999 at a total value of around Rs.60 lakhs only. The system is working satisfactory.

For SAINT-GOBAIN GLASS INDIA LTD.,

  
R.GLADSON BASKARAN  
HEAD-TECHNICAL SERVICES

**Saint-Gobain Glass India Ltd**  
Plot No 4-1, SECC Industrial Area, Sriperumbudur - 601 005, Chennai Region, Tamil Nadu  
Tel: (044) 3282216-25 Fax: (044) 3284148  
Regional Office: Saint-Gobain Village, 1st Floor, 12, Avenue 248/600 - 52100, Guwahati, Assam  
Phone: Inception 0361 272912-25

## Commissioning Certificate for ATC Tower, Bangalore Airport, India

 <b>LARSEN &amp; TOUBRO LIMITED</b> ECC DIVISION	<b>COMMISSIONING of</b> SAPPHIRE SYSTEM	
<b><u>COMMISSIONING OF SAPPHIRE SYSTEM AT BIAL SITE</u></b>		
Client	: LARSEN & TOUBRO LTD.-ECC DIV. (BIAL SITE)	
Contractor	: AGNICE FIRE PROTECTION LTD.	
Order No.	: LTCD / BUCC / EPNL / LOI / 4908 (dtd: 09/08/07)	
System	: SAPPHIRE SYSTEM FOR FIRE SUPPRESSION	
Location	: ATC TOWER	
Date	: 05 <sup>th</sup> April'08	

The Live Demonstration for Sapphire Fire Suppression System has been conducted in the presence of Representatives from BIAL, L&T and Agnice Fire Protection Ltd. The Controls for the entire system has been well explained by the Contractor's representatives and the live demonstration of the entire system commissioning has been found satisfactory.

**CLIENT'S REPRESENTATIVES:**

1. MR. KUNAL KUMAR ROY (L&T) *Kunal Roy*
2. MR. KRISHNA PRASAD (L&T) *Krishna Prasad*

**CONTRACTOR'S REPRESENTATIVES:**

1. MR. SHIV PRAKASH (AGNICE FIRE PROTECTION LTD.) *Shiv Prakash*



ERAM GROUP

# Appreciation Letter From AMANA, UAE

United Arab Emirates | Qatar | Kuwait | Saudi Arabia | Oman | Egypt | Sri Lanka

## TO WHOMSOEVER IT MAY CONCERN

P.O. Box: 27444  
Dubai, UAE  
Tel: +971 4 885 4448  
Fax: +971 4 885 9030

ص.ب.: 27444  
دبي، الإمارات العربية المتحدة  
هاتف: +971 4 885 4448  
فاكس: +971 4 885 9030

M/s. Bridgeway Electromechanical LLC are one of the leading MEP subcontractors in UAE. We, as main contractor, had appointed them as MEP subcontractor for several construction projects in UAE. Their quality of work, professionalism and timely completion of projects has been competent and reliable.

We have no hesitation to recommend them for any construction projects which require high professional standards and timely completion.

We are listing below a few prestigious Projects in which Bridgeway Electromechanical LLC, as MEP Contractor in UAE, were associated with us.

### 1. South Staff Accommodation Food Court

Contract Value : Dhs. 12,300,000.00  
Client : Jebel Ali Free Zone Authority  
Consultant : Bel Yoahah Architecture & Engineering Consultants  
Start Date : November 2008  
End Date : June 2009  
Location : JAFZA, Dubai, UAE

### 2. Goodrich MRO Facility at Jebel Ali Free Zone

Contract Value : Dhs. 8,700,000.00  
Client : Dubai Ports Authority  
Consultant : Scott Wilson Kirkpatrick & Co. Ltd.  
Start Date : November 2006  
End Date : July 2007  
Location : JAFZA, Dubai, UAE

### 3. Warehouse cum Office at Jebel Ali Free Zone South

Contract Value : Dhs. 4,950,000.00  
Client : Redington Gulf FZE  
Consultant : Orion Engineering Consultant  
Start Date : November 2009  
End Date : May 2010  
Location : JAFZA, Dubai, UAE

We wish them great success in all their endeavors.

Thanking you,

Regards,

For : Amana Steel Buildings Contracting LLC.

  
Jihad Bsaibes - General Manager  
Phone : +9714 885 4448  
Fax : +9714 885 9030  
Email : [jbsaibes@amanabuildings.com](mailto:jbsaibes@amanabuildings.com)  
Web : [www.amanabuildings.com](http://www.amanabuildings.com)



DUBAI



Amana Steel Buildings Contracting Co. LLC  
شركة الخدمات الفولاذية للمباني

# Appreciation Letter from System Construct

**SYSTEM  
CONSTRUCT** (LLC)

للإنشاءات (ش.م.ع)

Ref.: SYSCON/2010/MGT/ FC/L002  
Date: 19<sup>th</sup> May 2010

**To Whom It May Concern**

We, as Main Contractors, are associated with M/s. Bridgeway Electromechanical LLC as our regular MEP Subcontractor for the past 7 years. It is not an exaggeration when we say that our MEP Subcontractor M/s., Bridgeway Electromechanical LLC are very well known in the UAE market for their quality delivered on time with very high level of professionalism.

As our MEP Subcontractor, they have successfully completed the following prestigious projects, to the entire satisfaction of the consultants, clients and ourselves.

Sn.	Project	Consultant	Client	Value
1.	South Showroom, Offices and warehouses	Al Wasl Al Jadeed	JAFZA Engineering Dept.	41,058,600.00
2.	Porsche Showroom & Service Centre at Abu Dhabi	Arcan Project Management	Porsche	4,500,000.00
3.	Cold & Dry Store at DIP	Chawla Architects	Global shipping & logistics	3,700,000.00
4.	Lagoons Sales Centre	Consult Air	SAMA Dubai	15,500,000.00
5.	100 Warehouses for Abu Dhabi International Airport	Parsons International	Abu Dhabi Airport	17,475,900.00
6.	New workshop facility & Office Bldg at JAFZA	Al Saraya Engg.	National Oilwell	1,600,000.00
7.	West Staff Accommodation (G+3)	Al Wasl Al Jadeed	JAFZA	4,565,890.00
8.	Factory, Warehouse and Office Bldg at JAFZA	E-Home Engineering	Printpac	1,650,000.00
9.	Warehouse & Office Building at JAFZA	Chawla Architectural	Costra Advertising	2,759,000.00
10.	G+3 Labour accommodation	Bel Yoahah Architectural	Dubai Dry Dock	4,370,120.00

Last but not the least, our clients appreciate the quick response to any issues raised towards maintenance.  
With our best wishes to M/s. Bridgeway Electromechanical LLC for all their ventures in future.

Kind regards

For SYSTEM CONSTRUCT (LLC)

Fadi Chehabeddine  
Managing Director

Dubai H.O. P.O. Box: 9325 Tel: 04-3350303 Fax: 04-3353129  
Abu Dhabi P.O. Box: 7516 Tel: 02-6457503 Fax: 02-6457508  
Sharjah P.O. Box: 25046 Tel: 06-5731667 Fax: 04-3353129

Web: www.systemconstruct.com E-mail: info@system.ae

دبي: ص.ب. 9325 ت. 04-3350303 ف. 04-3353129  
أبوظبي: ص.ب. 7516 ت. 02-6457503 ف. 02-6457508  
الشارقة: ص.ب. 25046 ت. 06-5731667 ف. 04-3353129



ERAM GROUP

# Appreciation Letter from Al-Masaood Bergum



Abu Dhabi Office  
PO Box 322  
Abu Dhabi, U.A.E.  
Tel: (971-2) 6742 100  
Fax: (971-2) 6720 566  
E-mail: adoffice@amb.ae

Dubai Office  
PO Box 24059  
Dubai, U.A.E.  
Tel: (971-4) 88 02 626  
Fax: (971-4) 88 02 128  
E-mail: dxoffice@amb.ae

Qatar Office  
PO Box 22219  
Doha, Qatar  
Tel: (97-4) 465 9026  
Fax: (97-4) 465 9703  
E-mail: qatoffice@amb.ae

## TO WHOMSOEVER IT MAY CONCERN

This letter is intended to express our appreciation for the dedicated efforts, the hard work and the outstanding quality of service provided by Bridgeway Electromechanical LLC as MEP sub contractor in our various project in U.A.E.

We, as main contractor had appointed M/s. Bridgeway Electromechanical LLC as MEP Sub contractor in one of our prestigious projects viz Dubai Water Front-Anbar Low Cost Housing, Dubai (Value: 28,000,000.00) which was a very challenging project in terms of very short completion time and very high quality job. It is indeed a pleasure to congratulate them for their outstanding efforts in terms of speed and quality of the job undertaken and completed to the entire satisfaction of our clients and consultants.

We are listing below the other prestigious projects in U.A.E in which Bridgeway Electromechanical LLC as MEP sub contractor were associated with us.

- KHALIFA PORT AND INDUSTRIAL ZONE AT TAWEELAH, ABU DHABI
- JT METRO JV ACCOMODATION BUILDINGS( 4 NO'S)
- SEIMENS CAMP PROJECT, SHUWEIHAT, RUWAI, ABU DHABI
- ABU DHABI CULTURAL HEIRTAG, ABU DHABI
- OFFICE FOR SAMA DUBAI AT DUBAI LAGOONS, DUBAI

We wish them great success in all their endeavours.

Thanking you,

Yours faithfully,  
For AL MASAOD BERGUM LLC

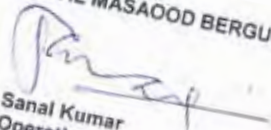
  
Sanal Kumar  
Operations Manager

شركة المسعود برغوم (ذ.م.ش)  
AL MASAOD BERGUM CO.  
TEL: 04 8802626 - 04 8802125  
FAX: 04 8802125  
P.O. BOX: 24059  
DUBAI - U.A.E.



[www.amb.ae](http://www.amb.ae)

# Site Photos of Oman OilTanking ODFJELL Terminals, Oman



# Site Photos of Oman OilTanking ODFJELL Terminals, Oman and JOTUN Warehouse facility, India



## Site Photos



**SAUDI ARABIA**

Eram Agnice Engineering  
 Khobar Business Gate Tower, A, 6th Floor,  
 P.O. Box: 4955 Al-Khobar 31952  
 Kingdom of Saudi Arabia  
 Tel.: +966 (3) 849 3636, Fax: +966 (3) 849 3880  
 E-mail: agnicearabia@agniceinternational.com

**SOUTH KOREA**

Eram Engineering Co.  
 #2205 Jamsil Resion  
 22-5 Bangi-Dong, Songpa-Gu  
 Seoul, Korea 138-953  
 Tel: +82 2 423 5703  
 Fax: +82 2 423 5704  
 E-mail: sales.kr@eram-international.com

**UNITED KINGDOM**

Eram Engineering Co.  
 5 th Floor, Stape Inn Building  
 ( North) HIG, London, WC 1V 7PZ,  
 United Kingdom  
 Tel: +44 2074 040222  
 Fax: +44 2074 040224  
 E-mail : uk@eramengineering.com

**ITALY**

Eram Engineering Co.  
 Via Passione 1, 20122 Milano, Italia  
 Tel : +39 02 86 72 59  
 Fax: +39 02 86 92 422  
 E-mail: italy@eramengineering.com

**INDIA**

Agnice Fire Protection Ltd.  
 2, First Main Road, G K Industrial Estate,  
 Alapakkam, Porur, Chennai - 600 116, Tamilnadu, India.  
 Tel: +91-44 2476 9323 / 4290 6900 (40 Lines)  
 Fax : +91-44 2476 9324  
 Email: marketing@agnice.net

**OMAN**

Agnice International & Partners LLC.,  
 P.O. Box 546, Postal Code: 117, Wadi Kabir,  
 Sultanate of Oman.  
 Tel : 00968 2479 7717  
 Fax : 00968 2479 9943  
 E-mail: agniceoman@manappat.com

**UAE**

Bridgeway Electromechanical LLC  
 P.O. Box 28737, Dubai, UAE  
 Tel: 00971 4 2683320  
 Fax: 00971 4 2683360  
 E-mail: agniceuae@manappat.com

**MUMBAI**

C301-303, III floor, Twin Arcade, Military Road,  
 Marol, Andheri East, Mumbai - 400059.  
 Tel: +91-22 4017 8500-14 Fax: +91-22 4017 8515,  
 Email: mumbai@agnice.net

**KOLKATA**

II Floor, AB-2, Sector 1 , Salt Lake City,  
 Kolkata - 700 064.  
 Tel: +91-33 4004 4681/82  
 Email : kolkata@agnice.net

**DELHI**

204, 2nd Floor, Kanchan House,  
 Karampura Commercial complex,  
 New Delhi - 110015.  
 Tel: +91-11 6595 5256 Fax: +91 -11 2592 0078,  
 Email: delhi@agnice.net

**HYDERABAD**

10-3-2/15, Sriपुरi Colony, East Marredpally,  
 Secunderabad, 500 026, Ap  
 Tel: +91-40 4202 4448  
 Email : hyderabadmarketing@agnice.net

**BANGLORE**

No. 5 , Vasants House, 2nd Floor, KHM Block,  
 R:T Nagar Main Road, Opp. New Shanthi  
 Sagar Hotel, R.T Nagar, Banglore - 560 032.  
 Tel : +91-080 4090 5788/99/89, Fax: 23437621  
 Email : banglore@agnice.net

**COCHIN**

II Floor, Babu's Estate, Madhava Pharmacy Junction,  
 Banerji Road, Cochin - 682 018  
 Tel: +91 -484 239 6842 fax: +91-484 239 1716  
 Email : kochi@agnice.net

